



**EN** Operating instructions. . . . .pages 1 to 13  
Original

**Content**

**1 About this document**

1.1 Function . . . . .1

1.2 Target group: authorised qualified personnel. . . . .1

1.3 Explanation of the symbols used . . . . .1

1.4 Appropriate use . . . . .1

1.5 General safety instructions . . . . .1

1.6 Warning about misuse . . . . .2

1.7 Exclusion of liability . . . . .2

**2 Product description**

2.1 Ordering code . . . . .2

2.2 Special versions. . . . .2

2.3 Purpose and use . . . . .2

**3 Technical data**

**4 Assembly**

4.1 General mounting instructions . . . . .3

4.2 Dimensions . . . . .4

4.3 Accessories . . . . .4

4.4 Switch distance . . . . .4

4.5 Adjustment. . . . .5

**5 Electrical connection**

5.1 General information for electrical connection. . . . .5

5.2 Requirements for the connected safety-monitoring module . . . . .5

5.3 Evaluation using device variants RSS 36...-F0/-F1/-Q . . . . .5

5.4 Serial diagnostic -SD . . . . .5

5.5 Wiring examples for series-wiring . . . . .6

5.6 Wiring configuration and connector plug accessories . . . . .9

**6 Actuator coding**

**7 Working principles and diagnostic function**

7.1 Mode of operation of the safety outputs. . . . .10

7.2 Diagnostic LED . . . . .10

7.3 Operating principle of the electronic diagnostic output . . . . .10

7.4 Safety-sensors with serial diagnostic function. . . . .11

**8 Set-up and maintenance**

8.1 Functional testing. . . . .12

8.2 Maintenance . . . . .13

**9 Disassembly and disposal**

9.1 Disassembly. . . . .13

9.2 Disposal . . . . .13

**10 Declaration of conformity**

**1. About this document**

**1.1 Function**

This operating instructions manual provides all the information you need for the mounting, set-up and commissioning to ensure the safe operation and disassembly of the safety switchgear.

**1.2 Target group: authorised qualified personnel**

All operations described in this operating instructions manual must be carried out by trained specialist personnel, authorised by the plant operator only.

Please make sure that you have read and understood these operating instructions and that you know all applicable legislations regarding occupational safety and accident prevention prior to installation and putting the component into operation.

The machine builder must carefully select the harmonised standards to be complied with as well as other technical specifications for the selection, mounting and integration of the components.

**1.3 Explanation of the symbols used**



**Information, hint, note:**

This symbol is used for identifying useful additional information.



**Caution:** Failure to comply with this warning notice could lead to failures or malfunctions.

**Warning:** Failure to comply with this warning notice could lead to physical injury and/or damage to the machine.

**1.4 Appropriate use**

The Schmersal range of products is not intended for private consumers.

The products described in these operating instructions are developed to execute safety-related functions as part of an entire plant or machine. It is the responsibility of the manufacturer of a machine or plant to ensure the correct functionality of the entire machine or plant.

The safety switchgear must be exclusively used in accordance with the versions listed below or for the applications authorised by the manufacturer. Detailed information regarding the range of applications can be found in the chapter "Product description".

**1.5 General safety instructions**

The user must observe the safety instructions in this operating instructions manual, labelled with the caution or warning symbol above, the country-specific installation standards as well as all prevailing safety regulations and accident prevention rules.



Further technical information can be found in the Schmersal catalogues or in the online catalogue on the Internet: [products.schmersal.com](http://products.schmersal.com).

The information contained in this operating instructions manual is provided without liability and is subject to technical modifications.

There are no residual risks, provided that the safety instructions as well as the instructions regarding mounting, commissioning, operation and maintenance are observed.

### 1.6 Warning about misuse



In case of improper use or manipulation of the safety switchgear, personal hazards or damages to machinery or plant components cannot be excluded.

### 1.7 Exclusion of liability

We shall accept no liability for damages or malfunctions resulting from defective mounting or failure to comply with this operating instructions manual. The manufacturer shall accept no liability for damages resulting from the use of unauthorised spare parts or accessories.

For safety reasons, invasive work on the device as well as arbitrary repairs, conversions and modifications to the device are strictly forbidden, the manufacturer shall accept no liability for damages resulting from such invasive work, arbitrary repairs, conversions and/or modifications to the device.

## 2. Product description

### 2.1 Ordering code

This operating instructions manual applies to the following types:

**RSS 36-①-②-③-④-⑤-⑥**

①	
without	Standard coding
I1	Individual coding
I2	Individual coding, multiple teaching
②	
without	Without diagnostic function (on request <sup>1)</sup> )
D	With diagnostic output
SD	With serial diagnostic function <sup>2)</sup>
③	
without	Standard version without feedback circuit monitoring EDM (External Device Monitoring)
F0	EDM with automatic reset <sup>2)</sup>
F1	EDM with manual reset <sup>2)</sup>
④	
without	Without acknowledgement function
Q	With acknowledgement function in case of input error via emergency stop <sup>2)</sup>
⑤	
without	Without latching
R	With latching, latching force approx. 18 N
⑥	
ST	Connector plug M12, 8-pole
ST5	Connector plug M12, 5-pole
(*)	
1)	only for version -ST5
2)	only for version -ST



Not all component variants, which are possible according to this order code are available and/or technically feasible.

#### Actuator

RST 36-1	Without latching
RST 36-1-R	With latching, latching force approx. 18 N

### 2.2 Special versions

For special versions, which are not listed in the ordering code, these specifications apply accordingly, provided that they correspond to the standard version.

### 2.3 Purpose and use

This non-contact, electronic safety sensor is designed for application in safety circuits and is used for monitoring the position of movable safety guards. In this application, the safety sensor monitors the position of hinged, sliding or removable safety guards by means of the coded electronic actuator.

The safety function consists of safely switching off the safety outputs when the safety guard is opened and maintaining the safe switched off condition of the safety outputs for as long as the safety guard is open.



The safety switchgears are classified according to ISO 14119 as type 4 interlocking devices. Designs with individual coding are classified as highly coded.

Safety sensors and actuators with latching (ordering suffix 'R') must always be used in pairs. The latching force (approx. 18 N) exercised by the permanent magnet keeps hatches and small guards closed, also in a de-energised condition.

The system can be used as a door end stop up to 5 kg at 0.25 m/s.

The diagnostic output of the safety sensor alternatively can be used as a conventional output or as a "serial output" with input and output channel.

#### Series-wiring

Series-wiring can be set up. In the case of a series connection, the risk time remains unchanged and the reaction time increases by the sum of the reaction time of the inputs per additional unit specified in the technical data. The quantity of devices is only limited by the cable drops and the external cable fuse protection, according to the technical data. Up to 31 device variants with serial diagnostics can be wired in series.



The user must evaluate and design the safety chain in accordance with the relevant standards and the required safety level. If multiple safety switchgears are involved in the same safety function, the PFH values of the individual components must be added.



The entire concept of the control system, in which the safety component is integrated, must be validated to the relevant standards.

3. Technical data

General data

Standards	EN ISO 13849-1, EN IEC 60947-5-3, EN IEC 61508
Coding level according to EN ISO 14119	I1-version: high I2-version: high Standard coding version: low

Working principle	RFID
Frequency band RFID	125 kHz
Transmitter output RFID, maximum	-6 dBm
Material of the housings	glass-fibre reinforced thermoplastic
Duration of risk, maximum	200 ms
Reaction time, switching off safety outputs via actuator, maximum	100 ms
Reaction time, switching off safety outputs via safety inputs, maximum	0.5 ms

Safety classification

Standards	EN ISO 13849-1, EN IEC 61508
Performance Level, up to	e
Category	4
PFH value	$2.70 \times 10^{-10}$ /h
PFD value	$2.10 \times 10^{-5}$
Safety Integrity Level (SIL), suitable for applications in	3
Mission time	20 years

Mechanical data

Latching force, approx.	18 N
Type of the fixing screws	2 x M4 cylinder head screw with washers to DIN 125A / Form A
Tightening torque for the fixing screws	2.2 ... 2.5 Nm

Mechanical data - switch distances according to EN IEC 60947-5-3

Switching distance, typically	12 mm
Assured switching distance "ON" $S_{ao}$	10 mm
Assured switching distance "OFF" $S_{ar}$	20 mm
Hysteresis (switching distance), maximum	2 mm
Repeat accuracy, maximum	0.5 mm

Mechanical data - Termination

Termination	
- ST	plug connector M12, 8-pole, A-coded,
- ST5	plug connector M12, 5-pole, A-coded
Notice (series-wiring)	Unlimited number of components, please observe external cable protection, max. 31 components in case of serial diagnostics SD
Length of the sensor chain	Cable length and cable section alter the voltage drop depending on the output current

Ambient conditions

Degree of protection	IP65, IP67, IP69
Ambient temperature	-28 °C ... +70 °C
Storage and transport temperature	-28 °C ... +85 °C
Relative humidity, maximum	93 %
Note (relative humidity)	non condensing, non icing
Resistance to vibration	10 ... 55 Hz, amplitude 1 mm
Resistance to shock	30 g / 11 ms
Protection class	III
Permissible installation altitude above sea level, max.	2,000 m

Ambient conditions - Insulation values

Rated insulation voltage $U_i$	32 VDC
Rated impulse withstand voltage $U_{imp}$	0.8 kV
Overvoltage category	III
Degree of pollution	3

Electrical data

Rated operating voltage	24 VDC -15 % / +10 % (stabilised PELV power supply)
Operating current, minimum	0.5 mA
No-load supply current $I_0$ , typically	35 mA
Rated operating current	600 mA
Required rated short-circuit current	100 A
Time to readiness, maximum	2,000 ms
Switching frequency, maximum	1 Hz
Utilisation category DC-12	24 VDC / 0.05 A
Electrical fuse rating, maximum	2 A

Electrical data - Safety digital inputs

Designation, Safety inputs	X1 and X2
Current consumption of the safety inputs	5 mA
Test pulse duration, maximum	1 ms
Test pulse interval, minimum	100 ms
Classification ZVEI CB24I, Sink	C1
Classification ZVEI CB24I, Source	C1, C2, C3

Electrical data - Safety digital outputs

Designation, Safety outputs	Y1 and Y2
Rated operating current	250 mA
Design of control elements	short-circuit proof, p-type
Voltage drop $U_{gt}$ , maximum	1 V
Leakage current $I_l$ , maximum	0.5 mA
Utilisation category DC-12	24 VDC / 0.25 A
Utilisation category DC-13	24 VDC / 0.25 A
Test pulse interval, typical	1000 ms
Test pulse duration, maximum	0.3 ms
Classification ZVEI CB24I, Source	C2
Classification ZVEI CB24I, Sink	C1, C2

Electrical data - Diagnostic outputs

Designation, diagnostic outputs	OUT
Design of control elements	short-circuit proof, p-type
Voltage drop $U_{gt}$ , maximum	2 V
Utilisation category DC-12	24 VDC / 0.05 A
Utilisation category DC-13	24 VDC / 0.05 A

Electrical data - Serial diagnostic SD

Designation, serial diagnostic SD	OUT
Operating current	150 mA
Design of control elements	short-circuit proof, p-type
Wiring capacitance	50 nF



This device complies with part 15 of the FCC Rules and contains licence-exempt transmitter(s)/receiver(s) that comply with Innovation, Science and Economic Development Canada's licence-exempt RSS(s):  
Operation is subject to the following two conditions:  
(1) This device may not cause harmful interference, and  
(2) this device must accept any interference received, including interference that may cause undesired operation.  
This device complies with the Nerve Stimulation Exposure Limits (ISED SPR-002) for direct touch operations. Changes or modifications not expressly approved by K.A. Schmersal GmbH & Co. KG could void the user's authority to operate the equipment.

L'émetteur/récepteur exempt de licence contenu dans le présent appareil est conforme aux CNR d'Innovation, Sciences et Développement économique Canada applicables aux appareils radio exempts de licence. L'exploitation est autorisée aux deux conditions suivantes:  
(1) L'appareil ne doit pas produire de brouillage.  
(2) L'appareil doit accepter tout brouillage radioélectrique subi, même si le brouillage est susceptible d'en compromettre le fonctionnement.  
Cet appareil est conforme aux limites d'exposition relatives à la stimulation des nerfs (ISED CNR-102) pour les opérations tactiles directes. Changements ou modifications non expressément approuvés par K.A. Schmersal GmbH & Co. KG pourraient annuler le droit de l'utilisateur à utiliser l'équipement.



Este equipamento não tem direito à proteção contra interferência prejudicial e não pode causar interferência em sistemas devidamente autorizados. Para maiores informações consultar:  
[www.gov.br/anatel](http://www.gov.br/anatel)

4. Assembly

4.1 General mounting instructions



Please observe the relevant requirements of the standards ISO 12100, ISO 14119 and ISO 14120.

Ensure the safety sensor and actuator is mounted on a flat surface. The component can be mounted in any position. The universal mounting holes provide for a variable mounting by means of M4 screws. Mounting: a screw length of 25 mm is sufficient for sensor mounting and for side mounting of the actuators. 30 mm long screws are recommended when the actuator is mounted upright and/or when the sealing discs are used. (Tightening torque 2.2...2.5 Nm). The labelled surfaces of the safety sensor and the actuator have to be opposite. The safety sensor must only be used within the assured switching distances  $\leq s_{ao}$  and  $\geq s_{ar}$ .



The actuator must be permanently fitted to the safety guards and protected against displacement by suitable measures (tamperproof screws, gluing, drilling of the screw heads).

To avoid any interference inherent to this kind of system and any reduction of the switching distances, please observe the following guidelines:

- The presence of metal chips in the vicinity of the sensor is liable to modify the switching distance.
- Keep away from metal chips.
- Minimum distance 100 mm between two safety sensors as well as other systems with same frequency (125 kHz)

### 4.2 Dimensions

All measurements in mm.

Safety sensor

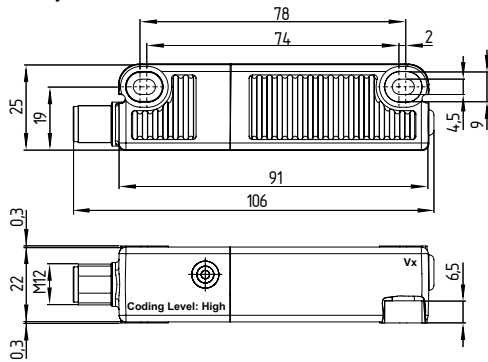

Actuator

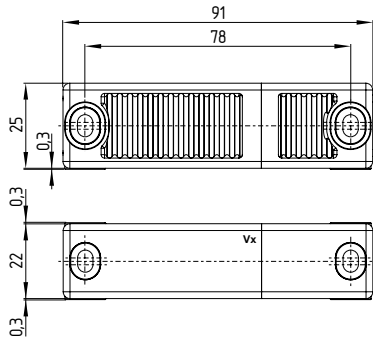

Alternative suitable actuators with different design: refer to [products.schmersal.com](http://products.schmersal.com).

### 4.3 Accessories

#### Set of disposal screws (to be ordered separately)

- 4 x M4x25 incl. washers, order number 101217746
- 4 x M4x30 incl. washers, order number 101217747

#### Sealing kit (to be ordered separately)

- Order number 101215048
- 8 plugs and 4 washers
- to seal the mounting holes and as spacer (approx. 3 mm) to facilitate the cleaning below the mounting surface
- also suitable as tampering protection for the screw fixings.



### 4.4 Switch distance

#### Switching distances in mm to EN 60947-5-3

Typical switching distance $s_{typ}$ :	12
Assured switching distance $s_{ao}$ :	10
Assured switch-off distance $s_{ar}$ :	20



There are new switch distances as per the table below owing to the necessity of technical modifications (as of V2). Please check the design of your guard system following installation to ensure adherence to the secured switch distances ( $\leq s_{ao}$  und  $\geq s_{ar}$ ) in accordance with the specified values and adjust the guard system accordingly. The positions of the designations Vx should be gleaned from the dimensional drawings.

Switching distances in mm to EN 60947-5-3	Actuator RST	Actuator RST as of V2
Sensor RSS	$s_{typ}$	12
	$s_{ao}$	10
	$s_{ar}$	16
Sensor RSS as of V2	$s_{typ}$	12
	$s_{ao}$	10
	$s_{ar}$	20



With the combination of old sensor and new actuator (as of V2) there may be limitations in availability owing to the reduced  $s_{ao}$  (8 mm). This change has no effect on the performance level.

The side allows for a maximum height misalignment (X) of sensor and actuator of  $\pm 8$  mm (e.g. mounting tolerance or due to guard door sagging). The axial misalignment (y) is max.  $\pm 18$  mm.

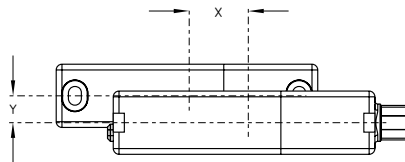

Latching versions  $X \pm 5$  mm,  $Y \pm 3$  mm. The latching force will be reduced by misalignment.

#### Actuating curves

The actuating curves represent the typical switching distance of the safety sensor during the approach of the actuator subject to the actuating direction

#### Transverse misalignment

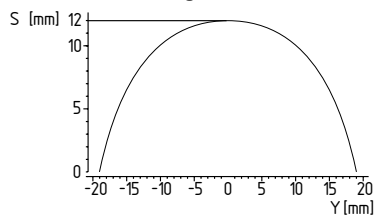

Height misalignment

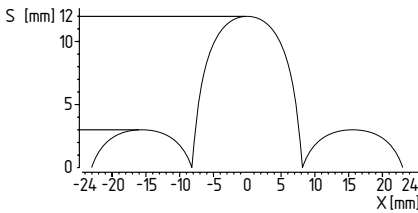

Preferred actuation directions: from front or from side

4.5 Adjustment

The continuous signal of the yellow LED signals the actuator detection; the flashing of the yellow LED signals that the safety sensor is actuated in the hysteresis area.



Recommended Adjustment

Align the safety sensor and actuator at a distance of  $0.5 \times s_{a0}$

The correct functionality of both safety channels must be checked by means of the connected safety-monitoring module.

5. Electrical connection

5.1 General information for electrical connection



The electrical connection may only be carried out by authorised personnel in a de-energised condition.

The safety outputs can be integrated into the safety circuit of the control system. For applications of PL e / category 4 to EN ISO 13849-1, the safety outputs of the safety sensor or of the sensor chain must be wired to a safety monitoring-module of the same category.

The required electrical cable fuse protection must be integrated in the installation.

Protection is not required when pilot wires are laid. The cables however must be separated from the supply and energy cables. The max. fuse rate for a sensor chain depends on the section of the connecting cable of the sensor.

5.2 Requirements for the connected safety-monitoring module

- Dual-channel safety input, suitable for p-type sensors with NO function



Information for the selection of suitable safety-monitoring modules can be found in the Schmersal catalogues or in the online catalogue on the Internet: [products.schmersal.com](http://products.schmersal.com).

The sensors cyclically switch off the safety output to test them. The safety-monitoring module therefore does not need to be equipped with a cross-wire short detection. The switch-off times must be tolerated by the safety-monitoring module. The switch-off time of the safety sensor is additionally extended depending on the cable length and the capacity of the cable used. Typically, a switch-off time of 250  $\mu$ s is reached with a 30 m connecting cable.



Configuration of the safety controller

If the safety sensor is connected to electronic safety-monitoring modules, we recommend that you set a discrepancy time of min. 100 ms. The safety inputs of the evaluation system should be able to suppress a test pulse of approximately 1 ms. The safety-monitoring module does not need to have a cross-wire short monitoring function, if necessary, the cross-wire short monitoring function must be disabled.

5.3 Evaluation using device variants RSS 36...-F0/-F1/-Q

As an alternative to an evaluation unit, the safety sensors of the RSS 36..F0 resp. RSS 36...F1 series can also be used for direct control and monitoring of safety contactors as first sensor of a series-wired chain.

With the F0/F1 option, the sensor performs the tasks of a safety-monitoring module. At both safety outputs, two auxiliary contactors<sup>1)</sup> or relays<sup>1)</sup> (each with positive-action contacts in accordance with EN 60947-5-1 or EN 50205) can be connected, whose safety-related function is checked by the sensor by means of a feedback circuit (External Device Monitoring). The feedback circuit includes the series-wiring of the NC contacts of the auxiliary contactors or relays. For the F0 version, an "enabling switch" (without safety function) can be integrated into the feedback circuit. For the F1 version, a so-called "reset button" is required, which is monitored for a trailing edge. This function corresponds to the "manual reset function" to EN ISO 13849-1.

The Q option monitors simultaneous shutdown of the sensor inputs. Series-wired sensors enable integration of emergency stop switching elements for applications to PL<sub>e</sub>. The emergency stop contacts are supplied by the cross-circuit monitored output signals of an upstream electronic safety switchgear device. At the end of the chain, a sensor with Q option for connecting an acknowledgement function monitors the chain for synchronous shutdown of both channels. In the event of erroneous shutdown, the error must be rectified. The safety outputs can be reactivated only once the error has been acknowledged.

5.4 Serial diagnostic -SD

Cable design

The wiring capacitance of the connecting cable of the safety sensor must not exceed 50 nF.

Depending on the strand structure, normal unshielded 200 m long control cables LIYY 0.25 mm<sup>2</sup> to 1.5 mm<sup>2</sup> have a wiring capacitance of approx. 20 ... 50 nF.



On wiring SD devices, please pay attention to the voltage drop on the cables and the current carrying capacity of the individual components.



Accessories for the series-wiring

For convenient wiring and series-wiring of SD components, the SD junction boxes PFB-SD-4M12-SD-V2 (variant for the field) and PDM-SD-4CC-SD (variant for control cabinet on carrier rail) are available along with additional comprehensive accessories. Detailed information is available on the Internet, [products.schmersal.com](http://products.schmersal.com).

5.5 Wiring examples for series-wiring

Series-wiring can be set up. In the case of a series connection, the risk time remains unchanged and the reaction time increases by the sum of the reaction time of the inputs per additional unit specified in the technical data. The number of components is only limited by the external cable protection according to the technical data and the line loss. Series-wiring of up to 31 RSS 36 ... SD components with serial diagnostics is possible.

The application examples shown are suggestions. They however do not release the user from carefully checking whether the switchgear and its set-up are suitable for the individual application.

**Wiring example 1: Series-wiring of the RSS 36 with conventional diagnostic output**

The voltage is supplied to both safety inputs of the last safety sensor of the chain (considered from the safety-monitoring module). The safety outputs of the first safety sensor are wired to the safety-monitoring module. The diagnostic output can be connected for instance to a PLC.

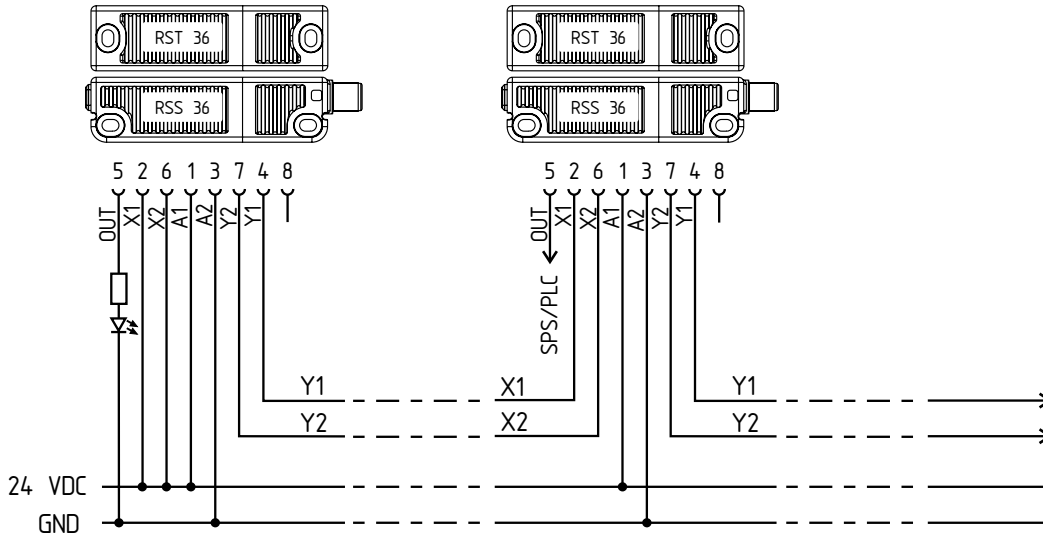

Y1 and Y2 = Safety outputs -> Safety-monitoring module

**Wiring example 2: series-wiring of the RSS 36 with serial diagnostic function**

In devices with the serial diagnostics function (ordering suffix -SD), the serial diagnostics connections are wired in series and connected to a SD-Gateway for evaluation purposes. The voltage is supplied to both safety inputs of the last safety sensor of the chain (considered from the safety-monitoring module).

The safety outputs of the first safety sensor are wired to the safety-monitoring module. The serial Diagnostic Gateway is connected to the serial diagnostic input of the first safety sensor.

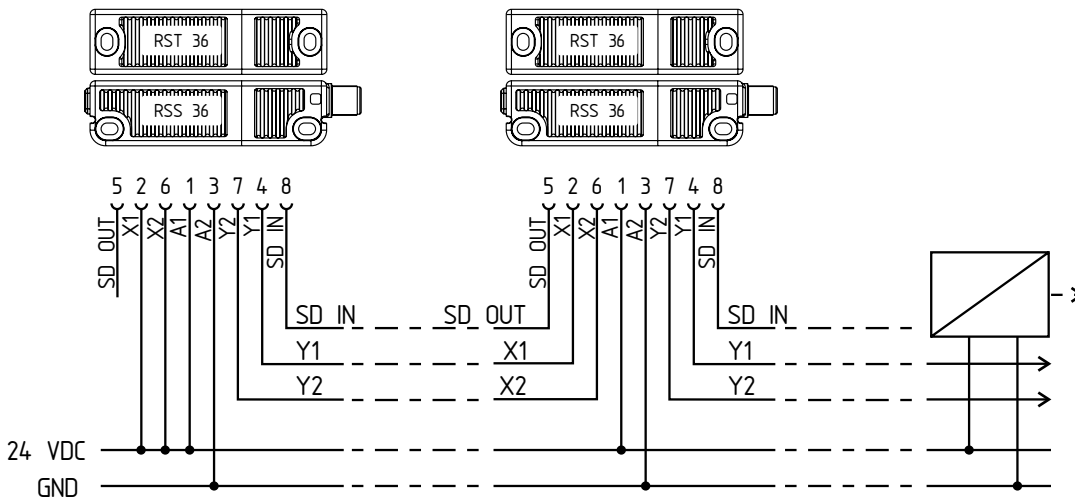

Y1 and Y2 = Safety outputs -> Safety-monitoring module

SD-IN -> Gateway -> Field bus

**Wiring example 3: series-wiring with RSS 36...F0**

The safety sensor RSS 36 ...F0 directly controls positive-action auxiliary contactors or relays. The monitoring of the external contactors or relays is enabled by the feedback circuit, which is built by the NC contacts of K1, K2. As no further button is used, the auxiliary contactors or relays are immediately enabled when the safety guard is closed. This kind of automatic reset is permissible only if a hazard from the machine starting up can be ruled out.

The feedback circuit can be extended by an enabling button. The sensor is switched on, as soon as the enabling button is pushed. The design then corresponds analogously to the wiring examples of the F1 variants. The internal safety-monitoring module of variant F0 is not equipped with an edge detection for the button. If required, a "manual reset" to EN ISO 13849-1 must be realised by other components of a local control system.

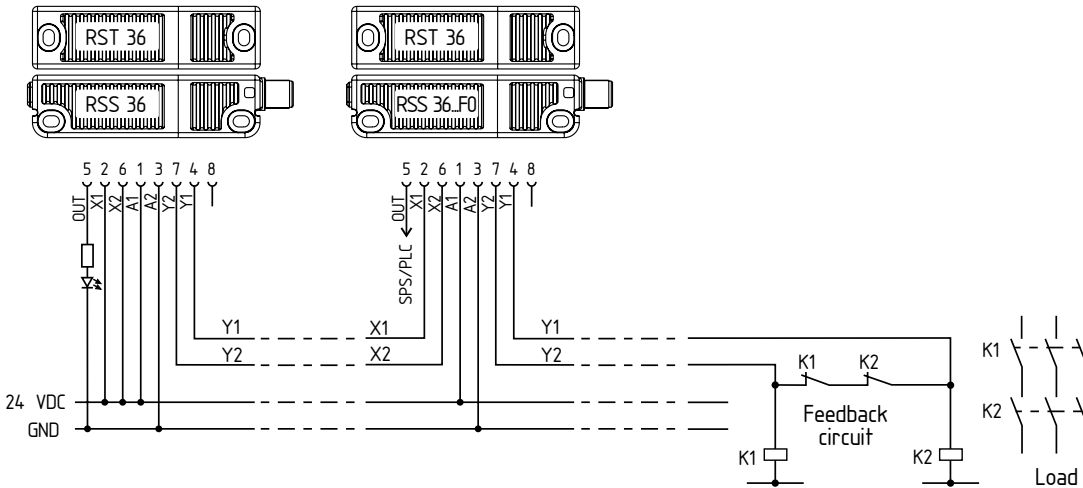

**Wiring example 4: series-wiring with RSS 36...F1-Q as master with EDM**

The safety sensor RSS 36 ...F1 directly controls positive-action auxiliary contactors or relays. The F1 function also monitors a trailing edge of the reset button in addition to the feedback contacts. The sensor switches on when the button is released. It can be used for manual reset on safety guards, which can be stepped over. The protected area must be designed so that a single reset button suffices. The Q function monitors emergency stop buttons integrated into the chain and requires a separate error acknowledgement button.

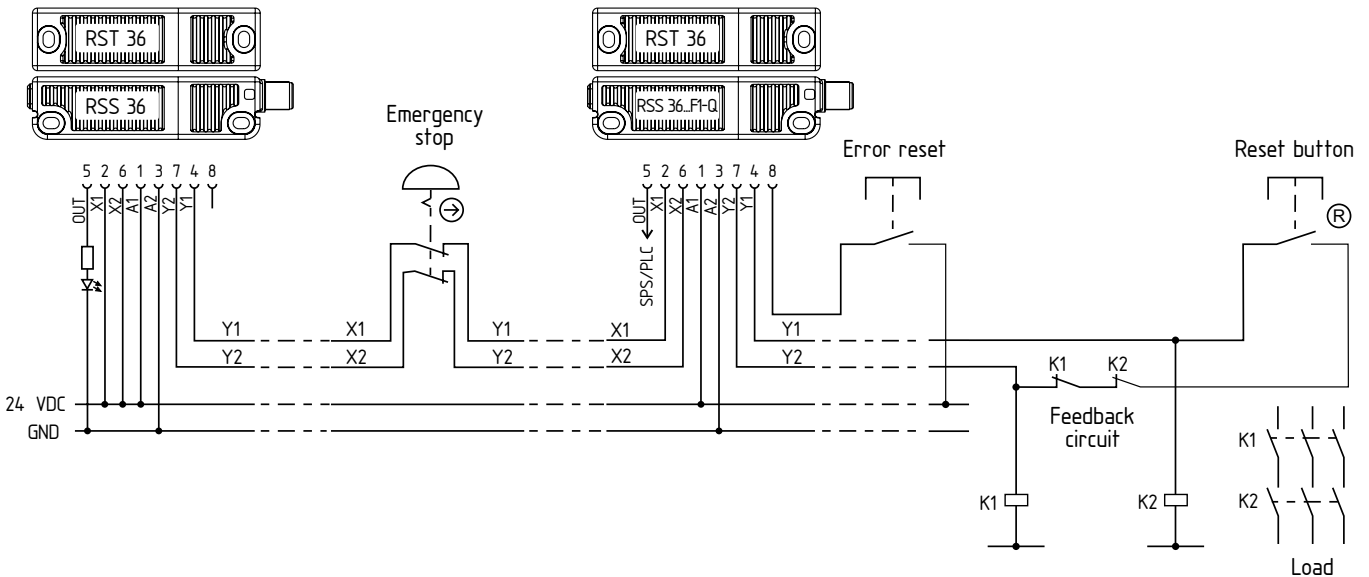

**Wiring example 5: series-wiring with RSS 36...SD-F1-Q as master with EDM and serial diagnostic function**

The safety sensor RSS 36 ...F1 directly controls positive-action auxiliary contactors or relays. The F1 function also monitors a trailing edge of the reset button in addition to the feedback contacts. The sensor switches on when the button is released. It can be used for manual reset on safety guards, which can be stepped over. The protected area must be designed so that a single reset button suffices. The Q function monitors the emergency stop buttons integrated into the chain. In the event of erroneous emergency stop signals, the error message must be reset via the serial diagnostic channel using Q monitoring.

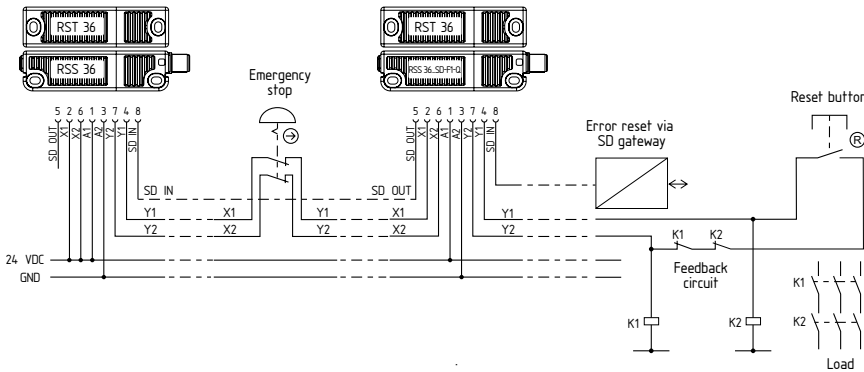

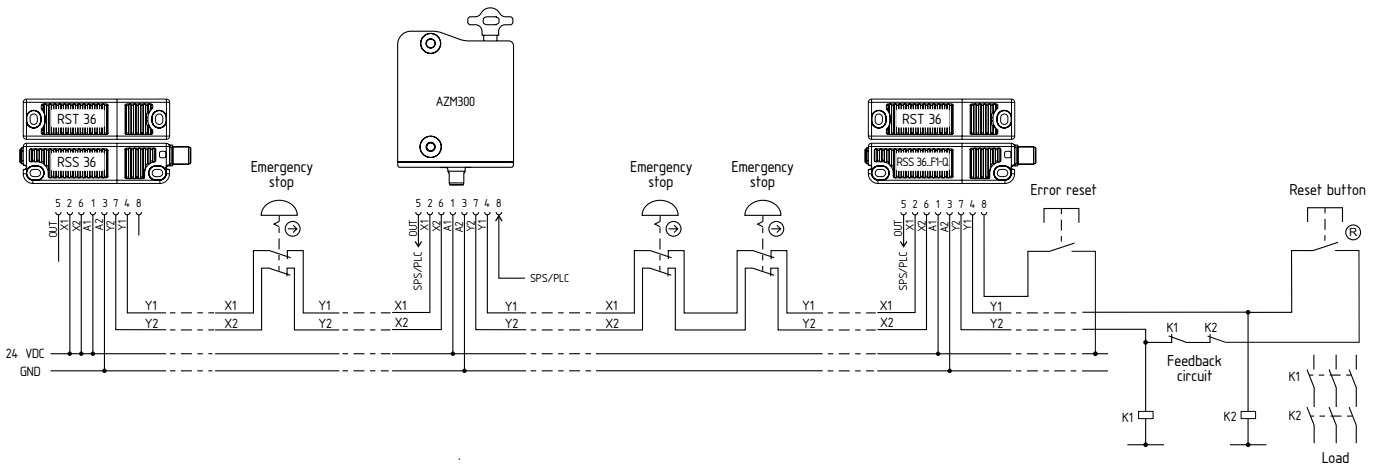

**Wiring example 6: series-wiring RSS 36...F1-Q with mixed components**

The safety sensor RSS 36 ...F1 directly controls positive-action auxiliary contactors or relays. The F1 function also monitors a trailing edge of the reset button in addition to the feedback contacts. The sensor switches on when the button is released. It can be used for manual reset on safety guards, which can be stepped over. The protected area must be designed so that a single reset button suffices. The Q function monitors emergency stop buttons integrated into the chain and requires a separate error acknowledgement button.



5.6 Wiring configuration and connector plug accessories

Function safety switchgear		Pin configuration of the connector		Colour code of conductor numbering of Schmersal connector plugs			Poss. colour code of other commercially available connector plugs to EN 60947-5-2	
		ST, 8-pole	ST5, 5-pole	ST, 8-pole		ST5, 5-pole		
	with conventional diagnostic output	with serial diagnostic function			IP67 / IP69 (PUR)	IP69 (PVC)	IP67 / IP69 (PUR)	
A1	U <sub>e</sub>		1	1	WH	BN	BN	BN
X1	Safety input 1		2		BN	WH		WH
A2	GND		3	3	GN	BU	BU	BU
Y1	Safety output 1		4	4	YE	BK	BK	BK
OUT	Diagnostic output	SD output	5	5	GY	GY	GY	GY
X2	Safety input 2		6		PK	VT		PK
Y2	Safety output 2		7	2	BU	RD	WH	VT
IN	without function	SD input	8		RD	PK		OR

Different pin assignment when using the Y distributor CSS-Y-8P Y for connection to the SD gateway.

CSS-Y-8P – Connector 2			Colour of wire		
Function	Pin assignment	Schmersal connector plug	Connector plug to DIN 47100	Connector plug to EN 60947-5-2	
A1	U <sub>e</sub>	1	BN	WH	BN
A1	U <sub>e</sub>	2	WH	BN	WH
A2	GND	3	BU	GN	BU
A2	GND	4	BK	YE	BK
Y1	Safety output 1	5	GY	GY	GY
Y2	Safety output 2	6	VT	PK	PK
IN	SD input	7	RD	BU	VT
OUT	SD output	8	PK	RD	OR

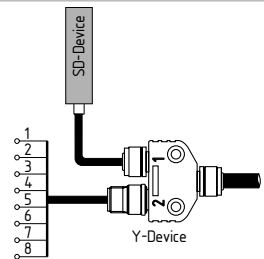

Connector accessories

Connecting cables (PUR) with coupling (female), IP67 / IP69, M12, 8-pin, 8 x 0.25 mm<sup>2</sup>, to DIN 47100

Cable length	Order number
2.5 m	103011415
5.0 m	103007358
10.0 m	103007359
15.0 m	103011414

Connecting cables (PVC) with coupling (female), IP69, M12, 8-pin, 8 x 0.21 mm<sup>2</sup>

Cable length	Order number
5.0 m	101210560
5.0 m, angled	101210561
10.0 m	103001389
15.0 m	103014823

Connecting cables (PUR) with coupling (female), IP67 / IP69, M12, 5-pole, 5 x 0.34 mm<sup>2</sup>, to EN 60947-5-2

Cable length	Order number
5.0 m	103010816
10.0 m	103010818
15.0 m	103010820

Connecting cables to connect to the safety fieldbox SFB IP67, M12, 8-pole – 8 x 0.25 mm<sup>2</sup>

Cable length	Order number
1.0 m	101217787
1.5 m	101217788
2.5 m	101217789
5.0 m	101217790

Protection is not required when pilot wires are laid. The cables however must be separated from the supply and energy cables. The required electrical cable fuse protection must be integrated in the installation. The max. fuse rate for a sensor chain depends on the section of the connecting cable of the sensor.

## 6. Actuator coding

Safety sensors with standard coding are ready to use upon delivery.

Individually coded safety sensors and actuators will require the following "teach-in" procedure:

1. Energise the safety sensor.
2. Introduce the actuator in the detection range. The teach-in procedure is signalled at the safety sensor, red LED on, yellow LED flashes (1 Hz).
3. After 10 seconds, brief cyclic yellow flashes (3 Hz) request the switch-off of the operating voltage of the safety sensor. (If the voltage is not switched off within 5 minutes, the safety sensor cancels the "teach-in" procedure and signals a false actuator by 5 red flashes.)
4. After the operating voltage is switched back on, the actuator must be detected once more in order to activate the taught actuator code. In this way, the activated code is definitively saved.

For ordering suffix -I1, the executed allocation of safety switchgear and actuator is irreversible.

For ordering suffix -I2, the "teach-in" procedure for a new actuator can be repeated an unlimited number of times. When a new actuator is taught, the code, which was applicable until that moment, becomes invalid. Subsequent to that, an enabling inhibit will be active for ten minutes, thus providing for an increased protection against tampering. The green LED will flash until the expiration of the time of the enabling inhibit and the detection of the new actuator. In case of power failure during the lapse of time, the 10-minute tampering protection time will restart.

## 7. Working principles and diagnostic function

### 7.1 Mode of operation of the safety outputs

The safety outputs can be integrated into the safety circuit of the control system. The opening of a safety guard, i.e. the actuator is removed out of the active zone of the sensor, it will immediately disable the safety outputs

### 7.2 Diagnostic LED

The safety sensor indicates the operating condition and faults by means of three-colour LEDs located in the lateral surfaces of the sensor.



The following LED indicators are the same for safety sensors with conventional diagnostic output as for those with a serial diagnostic function.

The green LED indicates that the safety sensor is ready for operation. The supply voltage is on and all safety inputs are present. Flashing (1Hz) of the green LED signals that a voltage is missing on one or both of the safety inputs (X1 and/or X2). The yellow LED always signals the presence of an actuator within range. If the actuator is operating near the limit of the hysteresis range of the safety sensor, the LED is flashing. The flashing can be used to prematurely detect variations in the clearance between the sensor and the actuator (e.g. sagging of a safety guard). The sensor must be adjusted before the distance to the actuator increases and before the safety outputs are disabled, thus stopping the machine. If an error is detected, the red LED will be activated.

LED indication (red)		Error cause
1 flash pulse		Error output Y1
2 flash pulses		Error output Y2
3 flash pulses		Cross-wire Y1/Y2
4 flash pulses		ambient temperature too high
5 flash pulses		Wrong or defective actuator
6 flash pulses		Discrepancy time error at X1/X2
Continuous red yellow LED flashing		Actuator teaching (if actuator within range)
Continuous red (possibly with yellow flashing LED)		Internal fault, with yellow flashing teaching procedure

### 7.3 Operating principle of the electronic diagnostic output

A diagnostic output additionally indicates the operating condition. These signals can be used in a downstream control.

The short-circuit proof diagnostic output OUT can be used for central visualisation or control functions, e.g. in a PLC.

**The diagnostic output is not a safety-related output.**

#### Error

Errors, which no longer guarantee the function of the safety sensor (internal errors) cause the safety outputs to be disabled within the risk time.

After the rectification of the error, the error message is reset by opening the corresponding safety guard.

#### Error warning

A fault that does not immediately endanger the safety function of the safety switchgear (e.g. too high ambient temperature, safety output at external potential, cross-circuit) leads to delayed shutdown. This signal combination, diagnostic output disabled and safety channels still enabled, can be used to stop the production process in a controlled manner. An error warning is deleted when the cause of error is eliminated. If the fault warning remains on for 30 minutes, the safety outputs are also switched off (red LED flashes).

Table 1: Examples of the diagnostic function of the safety-sensor with conventional diagnostic output

Sensor function	LED's			Diagnostic output	Safety outputs Y1, Y2	Comments
	Green	Red	Yellow			
I. Supply voltage	On	Off	Off	0 V	0 V	Voltage on, no evaluation of the voltage quality
II. Actuated	Off	Off	On	24 V	24 V	The yellow LED always signals the presence of an actuator within range.
III. Actuated, actuator in limit area	Off	Off	Flashes (1Hz)	24 V pulsed	24 V	The sensor must be adjusted before the distance to the actuator increases and before the safety outputs are disabled, thus stopping the machine.
IV. Internal error or in the event of simultaneous flashing, teach-in process	On	Off	Flashes (5 Hz)	24 V	0 V	The sensor waits for a signal at the feedback circuit: F0: Closing of the feedback circuit F1: Trailing edge at feedback circuit
V. Actuated in limit area and feedback circuit open	On	Off	Flashes alternately (1 Hz / 5 Hz)	24 V pulsed	0 V	LED indication combines the sensor functions III. and IV.
VI. Error warning, sensor actuated	Off	Flashes	Off	0 V	24 V	After 30 minutes if the error is not rectified
VII. Error	Off	Flashes / on	Off / flashes	0 V	0 V	Refer to table with flash codes
VIII. Teach actuator	Off	On	Flashes	0 V	0 V	Sensor in teaching mode
IX. Protection time	Flashes	Off	Off	0 V	0 V	10 minutes pause after re-teaching
X. No input signal at X1 and/or X2	Flashes (1Hz)	Off	Off	0 V	0 V	Example: door open; a door in the safety circuit upstream is also open.
XI. No input signal at X1 and/or X2	Flashes (1Hz)	Off	On	24 V	0 V	Example: door closed, a door in the safety circuit upstream is open.

#### 7.4 Safety-sensors with serial diagnostic function

Safety sensors with serial diagnostic cable have a serial input and output instead of the conventional diagnostic output. If RSS / CSS safety sensors are wired in series, the safety channels as well as the inputs and outputs of the diagnostic channels are wired in series.

Max. 31 safety switchgear with serial diagnostics can be wired in series. For the evaluation of the serial diagnostics line either the PROFIBUS-Gateway SD-I-DP-V0-2 or the Universal-Gateway SD-I-U-... are used. This SD-Gateway is integrated as a slave in an existing field bus system. In this way, the diagnostic signals can be evaluated by means of a PLC. The necessary software for the integration of the SD-Gateway is available for download at [products.schmersal.com](http://products.schmersal.com).

The response data and the diagnostic data are automatically and permanently written in the assigned input byte of the PLC for each safety sensor in the series-wired chain.

The request data for each safety sensor are transmitted to the device through an output byte of the PLC.

In the event of a communication error between the SD-Gateway and the safety sensor, the switching condition of the safety output of the safety sensor is maintained.

- Bit 0: safety outputs enabled
- Bit 1: safety sensor actuated, actuator identified
- Bit 3: feedback circuit open or reset button not actuated
- Bit 4: both safety inputs live
- Bit 5: safety sensor actuated in hysteresis area
- Bit 6: error warning, switch-off delay activated
- Bit 7: error, safety outputs switched off

#### Error

Errors which no longer guarantee the function of the safety switchgear (internal errors) cause the safety outputs to be disabled within the duration of risk. The fault is reset, when the cause is eliminated and bit 7 of the request byte changes from 1 to 0 or the safety guard is opened. Faults at the safety outputs are only deleted upon the next release, as the fault rectification cannot be detected sooner.

#### Error warning

A fault that does not immediately endanger the safety function of the safety switchgear (e.g. too high ambient temperature, safety output at external potential, cross-circuit) leads to delayed shutdown. This signal combination, diagnostic output disabled and safety channels still enabled, can be used to stop the production process in a controlled manner.

An error warning is deleted when the cause of error is eliminated. If the fault warning remains on for 30 minutes, the safety outputs are also switched off (red LED flashes).

#### Diagnostic error (warning)

If an error (warning) is signalled in the response byte, detailed fault information can be read out.



Detailed information about the use of the serial diagnostics can be found in the operating instructions of the PROFIBUS-Gateway SD-I-DP-V0-2 and the Universal-Gateway SD-I-U-....

Table 2: Function of the visual diagnostic LEDs, the serial status signals and the safety outputs by means of an example

System condition	LED's			Safety outputs Y1, Y2	Status signals serial diagnostic byte Bit n°							
	green	red	yellow		7	6	5	4	3	2	1	0
Non-actuated, inputs X1 and X2 enabled	On	Off	Off	0 V	0	0	0	1	0	0	0	0
Actuated, feedback circuit open / not actuated	On	Off	Flashes (5Hz)	0 V	0	0	0	1	1	0	1	0
Actuated, safety outputs enabled	Off	Off	On	24 V	0	0	0	1	0	0	1	1
Actuated in limit area	Off	Off	Flashes (1Hz)	24 V	0	0	1	1	0	0	1	1
Actuated, warning	Off	On/flashes	Off	24 V	0	1	0	1	0	0	1	1
Actuated, fault	Off	On/flashes	Off	0 V	1	1	0	1	0	0	1	0

The shown bit order of the diagnostic byte is an example. A different combination of the operational conditions will lead to a change of the bit order.

Table 3: Tabular overview of status signals, warnings or error messages  
(The described condition is reached, when Bit = 1)

Communication directions: Request byte: from the PLC to the local safety sensor  
Response byte: from the local safety sensor to the PLC  
Warning/error byte: from the local safety sensor to the PLC

Bit n°	Request byte	Response byte	Diagnostic	
			Error warnings	Error messages
Bit 0:	—	Safety output activated	Error output Y1	Error output Y1
Bit 1:	—	Actuator detected	Error output Y2	Error output Y2
Bit 2:	—	—	Cross-wire Y1/Y2	Cross-wire Y1/Y2
Bit 3:	—	—	Temperature too high	Temperature too high
Bit 4:	—	Input condition X1 and X2	—	Wrong or defective actuator
Bit 5:	—	Actuated in limit area	Internal device error	Internal device error
Bit 6:	Error acknowledgement, Discrepancy time exceeded	Error warning	Communication error between the field bus Gateway and the safety sensor	Error, discrepancy time exceeded at X1/X2
Bit 7:	Error reset	Error (enabling path switched off)	—	—

## 8. Set-up and maintenance

### 8.1 Functional testing

The safety switchgear must be tested with regard to its safety function.

The following conditions must be previously checked and met:

1. Fitting of the sensor and the actuator.
2. Fitting and integrity of the power cable.
3. The system is free of dirt and soiling (in particular metal chips).

### Functional test after assembly and connection of the RSS36 ...F0/-F1

All safety guards must be closed prior to the start of the functional test. The feedback circuit must be opened. <sup>1)</sup>

No.	Action to test the operation	Reaction RSS 36 F0 version	Reaction RSS 36 F1 version
1	Switch on the operating voltage	The yellow LED flashes at 5 Hz and the relays are disabled.	The yellow LED flashes at 5 Hz and the relays are disabled.
2	Close the feedback circuit: actuate the connected button <sup>2)</sup>	The yellow LED is on and both connected relays are enabled	No change compared to 1
3	Only version F1: reset button actuation	No change compared to 2	The yellow LED is on and both connected relays are enabled

<sup>1)</sup> If no button is used, the feedback circuit must be opened by loosening the cable. To that effect, the voltage must be switched off.

<sup>2)</sup> If no button is used, the feedback circuit must be closed by reconnecting the cable. To that effect, the voltage must be switched off.

With the F1 function, the button monitored for the trailing edge must be pressed.

A non-monitored button integrated into the feedback circuit with function F0 is already effective on closing.

Emergency stop switching elements integrated into a series circuit can be monitored by the Q function of the last sensor in the chain. This monitors the simultaneous shutdown of its safety inputs and closes the safety outputs in the event of deviations greater than 500 ms. A malfunction in the chain detected in this way must be rectified immediately. Release is only then possible after the error has been acknowledged. The error will remain saved even in the event of a power interruption. The error must be acknowledged via the negative edge of an acknowledgement button connected to PIN 8 or via the serial diagnostic cable.

Additionally, a reset button must be provided in the event of integration of emergency stop switching elements as after withdrawal of an emergency stop command, no automatic restart of the machine is permissible.

According to the test interval outlined in the chapter Maintenance, the emergency stop switching elements monitored in this way satisfy the requirements to PL e.

### 8.2 Maintenance

In the case of correct installation and adequate use, the safety sensor features maintenance-free functionality.

A regular visual inspection and functional test, including the following steps, is recommended:

1. Check the fitting and integrity of the safety sensor, the actuator and the cable.
2. Remove possible metal chips.



Adequate measures must be taken to ensure protection against tampering either to prevent tampering of the safety guard, for instance by means of replacement actuators.



Emergency stop switching elements integrated into a series circuit with Q monitoring must have their function checked manually on a regular basis. An annual inspection is sufficient for a typical Cat. 3/PL d application. A monthly inspection is required for a typical Cat. 4/PL e application.



Damaged or defective components must be replaced.

**K.A. Schmersal GmbH & Co. KG**  
Mödinghofe 30, 42279 Wuppertal  
Germany  
Phone: +49 202 6474-0  
Telefax: +49 202 6474-100  
E-Mail: [info@schmersal.com](mailto:info@schmersal.com)  
Internet: [www.schmersal.com](http://www.schmersal.com)

## 9. Disassembly and disposal

### 9.1 Disassembly

The safety switchgear must be disassembled in a de-energised condition only.

### 9.2 Disposal



The safety switchgear must be disposed of in an appropriate manner in accordance with the national prescriptions and legislations.

## 10. Declaration of conformity

We hereby certify that the hereafter described components both in their basic design and construction conform to the applicable European Directives.

### Relevant Directives:

2006/42/EC	SI 2008/1597
2014/53/EU	SI 2017/1206
2011/65/EU	SI 2012/3032

### Applied standards:

EN 60947-5-3:2013
ISO 14119:2013
EN 300 330 V2.1.1:2017
EN ISO 13849-1:2023
IEC 61508 parts 1-7:2010

### Notified body for Type Examination:



TÜV Rheinland  
Industrie Service GmbH  
Am Grauen Stein  
51105 Köln  
ID n°: 0035

### EC-Type Examination Certificate:

01/205/5115.03/24



TÜV Rheinland UK Ltd.  
1011 Stratford Road  
Solihull, B90 4BN  
ID n°: 2571

01/205U/5115.01/25



The currently valid declaration of conformity can be downloaded from the internet at [products.schmersal.com](http://products.schmersal.com).