



EN Operating instructions pages 1 bis 10
Original

Content

1 About this document

1.1 Function 1

1.2 Target group: authorised qualified personnel. 1

1.3 Explanation of the symbols used 1

1.4 Appropriate use 1

1.5 General safety instructions 1

1.6 Warning about misuse 1

1.7 Exclusion of liability 2

2 Product description

2.1 Ordering code 2

2.2 Purpose and use 2

2.3 Technical data 2

3 Assembly

3.1 General mounting instructions 2

3.2 Dimensions 2

4 Electrical connection

4.1 General information for electrical connection. 3

4.2 Coding of connecting terminals 3

5 Installation and operation

5.1 Installation SD interface 3

5.2 Installation field bus 3

5.3 Description of the terminals and LED indications 3

5.4 MAC addresses 4

5.5 Web server. 4

6 Operation of SD bus and communication

6.1 Teach-in of safety switchgear devices via SD interface. 6

6.2 Communication with external PLC via field bus. 6

6.3 Cyclical communication 7

6.4 Acyclic communication and individual activation of SD devices . . . 7

7 Wiring example

7.1 Series wiring evaluation. 8

8 Diagnostic

8.1 LED indications 9

8.2 Faults 9

9 Set-up and maintenance

9.1 Commissioning 9

9.2 SDG commissioning 9

9.3 Functional testing. 9

9.4 Behaviour in the case of faults. 9

10 Disassembly and disposal

10.1 Disassembly 9

10.2 Disposal. 9

11 EU Declaration of conformity

1. About this document

1.1 Function

This operating instructions manual provides all the information you need for the mounting, set-up and commissioning to ensure the safe operation and disassembly of the switchgear. The operating instructions must be available in a legible condition and a complete version in the vicinity of the device.

1.2 Target group: authorised qualified personnel

All operations described in this operating instructions manual must be carried out by trained specialist personnel, authorised by the plant operator only.

Please make sure that you have read and understood these operating instructions and that you know all applicable legislations regarding occupational safety and accident prevention prior to installation and putting the component into operation.

The machine builder must carefully select the harmonised standards to be complied with as well as other technical specifications for the selection, mounting and integration of the components.

1.3 Explanation of the symbols used



Information, hint, note:

This symbol indicates useful additional information.



Caution: Failure to comply with this warning notice could lead to failures or malfunctions.

Warning: Failure to comply with this warning notice could lead to physical injury and/or damage to the machine.

1.4 Appropriate use

The Schmersal range of products is not intended for private consumers.

The product must be exclusively used in accordance with the versions listed below or for the applications authorised by the manufacturer. Detailed information regarding the range of applications can be found in the chapter "Product description".

1.5 General safety instructions

The user must observe the safety instructions in this operating instructions manual, the country specific installation standards as well as all prevailing safety regulations and accident prevention rules.



Further technical information can be found in the Schmersal catalogues or in the online catalogue on the Internet: products.schmersal.com.

The information contained in this operating instructions manual is provided without liability and is subject to technical modifications.

There are no residual risks, provided that the safety instructions as well as the instructions regarding mounting, commissioning, operation and maintenance are observed.

1.6 Warning about misuse



In case of inadequate or improper use or manipulations of the component, personal hazards or damage to machinery or plant components cannot be excluded.

1.7 Exclusion of liability

We shall accept no liability for damages and malfunctions resulting from defective mounting or failure to comply with this operating instructions manual. We shall accept no liability for damages and malfunctions resulting from defective mounting or failure to comply with this operating instructions manual.

For safety reasons, invasive work on the device as well as arbitrary repairs, conversions and modifications to the device are strictly forbidden, the manufacturer shall accept no liability for damages resulting from such invasive work, arbitrary repairs, conversions and/or modifications to the device.

2. Product description

2.1 Ordering code

This operating instructions manual applies to the following types:

SDG-①-②-③

No.	Option	Description
Field bus interface		
①	ETC	EtherCAT
	PRN	Profinet
	EIP	Ethernet/IP
	MBT	Modbus TCP
	OPU	OPC UA
	IOL	IO Link
Diagnostic interface		
②	RJ	RJ45
	BT	Bluetooth
③		Plug-in screw clamps: single wire (rigid) or fine wire (flexible): 0.2 ... 2.5 mm ² ; fine wire with ferrule: 0.25 ... 2.5 mm ²
	CC	Plug-in cage clamps: single wire (rigid) or fine wire (flexible): 0.2 ... 1.5 mm ² ; fine wire with ferrule: 0.25 ... 1.5 mm ²

2.2 Purpose and use

The SDG field bus gateway is used in conjunction with safety sensors, solenoid interlocks and control panels with serial diagnostics. In these components, the diagnostic output is replaced with a serial input and output cable. If components with serial diagnostics are wired in series, the inputs and outputs of the diagnostic channels as well as the safety circuits are wired in series.

In this way, a series-wired chain of a maximum 31 devices can be set up. For the evaluation, the serial diagnostic cable is connected to the here-described field bus gateway. The gateway converts the serial information of the series wiring into the corresponding field bus protocol. The gateway is integrated as a slave into the available field bus system. The diagnostics signals of all SD devices can be evaluated by the control system via the field bus master. Operational conditions can be read and control commands e.g. to unlock a solenoid interlock, which is installed on the components of the series-wired chain, can be transmitted. The status or failure information of each individual component of the series-wired chain is automatically loaded in the PLC.



The field bus gateway does not realise safety tasks. The safety monitoring of the safety switching appliances must be realised independently.



The unit is in compliance with EN 61131-2 clauses 5.11, 7.8.2 and 8.3 and IEC 61131-2 clauses 8.2.1, 8.3, 7.2 and 7.3.

2.3 Technical data

General data

Standards:	EN 61131-2, IEC 61131-2
EMC rating:	to EMC Directive
Electromagnetic interference:	to EMC Directive
Air clearances and creepage distances:	according to EN 60664-1
Mounting:	standard rail to EN 60715
Terminal designations:	EN 60947-1

Electrical characteristics:

Rated operating voltage U _e :	24 VDC (-15 %/+20 %)
Mains adapter/power supply:	an ES1 or PELV/SELV mains adapter must be used as a voltage source or be ensured by means of additional measures so that the output voltage of the power adapter in the event of an error does not exceed 60 V. Mains power supply must harmonise with device safety (characteristic/melting property) so that triggering is ensured.
Fuse rating for the operating voltage:	3 A (internal)
Current consumption at 24 V/DC:	max. 150 mA

Insulation values to EN 60664-1:

- Rated insulation voltage U _i :	32 V/DC
- Rated impulse withstand voltage U _{imp} :	500 kV
- Over-voltage category:	III
- Degree of pollution:	2

Time to readiness after switch-on: 8 s (by software)

Permanent memory: SD card, no battery

Mechanical data:

Connection type:	refer to 2.1
Cable section:	refer to 2.1
Connecting cable:	rigid or flexible
Tightening torque for the terminals:	0.5 Nm
Material of enclosure:	glass-fibre reinforced thermoplastic, ventilated
Weight:	127 g

Ambient conditions:

Ambient temperature:	0 °C ... +55 °C, with vertical (normal) installed position
Storage and transport temperature:	-25 °C ... +75 °C
Relative humidity:	5 % ... 95 %, non condensing
Degree of protection:	Enclosure: IP40 Terminals: IP20 Clearance: IP54

Continuous shock resistance: 10 g / 6 ms

Resistance to shock: 15 g / 11 ms

Resistance to vibration: 10 ... 55 Hz,

Amplitude 0.35 mm

57 Hz ... 150 Hz, 5 g

Altitude: max. 2,000 m



All connected wires need to be rated at 65°C minimum. Only use copper conductors. The product shall be provided with an enclosure suitable for the end use application. IP rating was not evaluated by UL.



The third-party software components used, and their respective licensing conditions, can be found at products.schmersal.com.

3. Assembly

3.1 General mounting instructions

Mounting: snaps onto standard DIN rails to EN 60715.

Hook bottom of enclosure in standard rail and push down until it engages in position.

3.2 Dimensions

Device dimensions (H/W/D): 98 x 22.5 x 115 mm

4. Electrical connection

4.1 General information for electrical connection



The electrical connection may only be carried out by authorised personnel in a de-energised condition.



If mains unit is a new installation or a replacement, the connector of the output level must be removed and correct connection of the power supply (A1) must be checked.



Only touch the components after electrical discharge.



To avoid EMC disturbances, the physical ambient and operational conditions at the place where the product is installed, must meet the provisions laid down in the paragraph "Electromagnetic Compatibility (EMC)" of EN 60204-1.



The SDG and all SD slaves must be connected to the same 24 V/DC supply.



The device may be damaged if it is supplied with alternating current voltage.



If the polarity of the supply voltage is reversed, the device cannot be operated.



Switching the supply voltage off and on again restarts all services.



The device switches off if the supply voltage falls below a level of 19.2 V. The device may be damaged if the supply voltage exceeds a level of 30 V.



The longest interruption time for the supply voltage is 10 ms.

Settle length x of the conductor:

- on screw terminals: 7 mm
- on cage clamps of type s or f: 10 mm



The SD interface is wired via standard control lines. The SD interface connecting cable connected to the UNIVERSAL gateway must have a maximum length of 200 m; its wiring capacitance must not exceed 60 nF. Standard control lines of type LiYY or H05VV-F with cross sections of 0.25 mm² to 1.5 mm² (AWG16 – AWG24) have a wiring capacitance of approx. 30 ... 45 nF with a length of 200 m.

For assignment of terminals, see Section 5.3.

4.2 Coding of connecting terminals

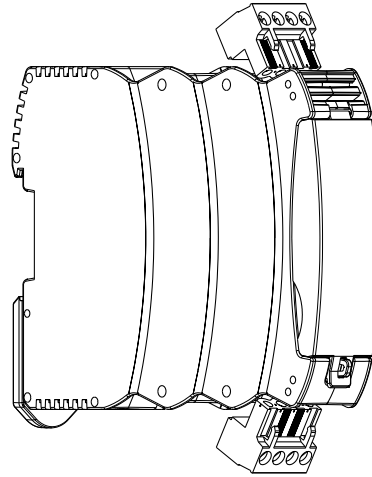

5. Installation and operation

5.1 Installation SD interface

Electronic safety sensors and interlocks must be interconnected according to the technical data of the individual sensors. The safety and diagnostics channels are configured with series wiring. To this end, the serial diagnostics cable is connected from device to device and fed to the SD terminal of the SD gateway. The SD connection of the SD gateway is connected to the SD input on the first device in series. The SD output on the first device is connected to the SD input on the following device, and so on. The output on the final device is unused. Under no circumstances may the operating voltage or GND be connected to this output.

For a wiring example, see Section 7.1.

5.2 Installation field bus

The field bus should be connected to the designated sockets on the SDG with standard field bus cables and RJ45 connector plugs.



The specifications for installation of the respective field bus system must be observed.

5.3 Description of the terminals and LED indications

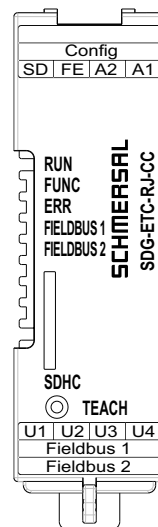

Figure 1: SDG front panel with LED and connection terminal designations

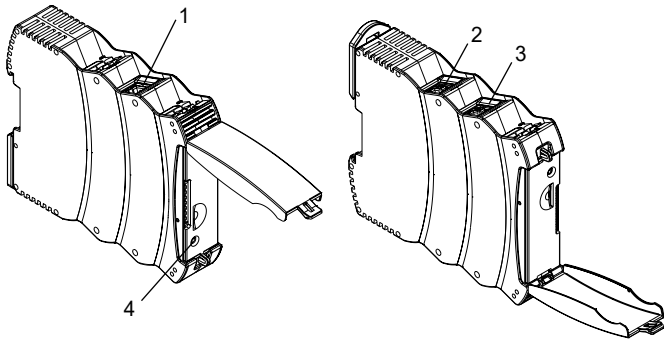

Figure 2: Top of SDG (left) and bottom of SDG (right) (position 1-4, see Table 1)

Table 1: Terminal and functional description

Clip (Pos.)	Function
A1	Operating voltage +24 VDC
A2	Operating voltage 0 V
FE	Functional earth connection
SD	SD bus
Config (1)	Diagnostic and configuration interface
U1	n.c.
U2	n.c.
U3	n.c.
U4	n.c.
Field bus 2 (3)	SDG-ETC-...: EtherCAT Out SDG-PRN-...: Profinet 1
Field bus 1 (2)	SDG-ETC-...: EtherCAT In SDG-PRN-...: Profinet 2
TEACH (4)	"TEACH" button for teaching in the SD chain
SDHC	SD card

The FE connection (functional ground) must be connected to PE.

If A2 and PE do not have a connection, FE must be connected to A2.

Table 2: LED indications

LED	Function	Display	Comment
RUN	Ready for operation/voltage present	Lights up "GREEN"	
	Over/under voltage detected	Lights up "RED"	
	Factory reset in progress	Flashes "RED" and flashes "GREEN"	
	No voltage connected	"OFF"	
FUNC	Teach-in is required/actual and setpoint configuration do not match	Flashes "YELLOW"	
	No SD chain connected or SD chain interrupted during operation	Lights up "YELLOW"	

LED	Function	Display	Comment
ERR	Teach-in process running	Flashes "YELLOW"	
	SD-Short-circuit	Flashes "RED"	
	SD voltage, data quality not good or SD chain interrupted during operation	Flashes "YELLOW"	
	Actual and setpoint configuration do not match	Lights up "RED"	
Field bus LED 1	Function and designation according to respective field bus specification		SDG-ETC-...: EC RUN SDG-PRN-...: DCP
Field bus LED 2	Function and designation according to respective field bus specification		SDG-ETC-...: EC ERR SDG-PRN-...: BUS ERR

5.4 MAC addresses

The device has up to four separate MAC addresses.

1. Diagnosis and configuration interface (MAC address is specified on the type plate)
2. Internal MAC address of field bus controller, if appl., (equivalent to value 1.) incremented by the value 1)
3. MAC address of field bus 1 interface, if appl., (equivalent to value 1.) incremented by the value 2)
4. MAC address of field bus 2 interface, if appl., (equivalent to value 1.) incremented by the value 3)

Example: The MAC address specified on the type plate is XX:XX:XX:XX:XX:3C, so the other MAC addresses are calculated as follows:

- Internal network controller: XX:XX:XX:XX:XX:3D
- Field bus 1: XX:XX:XX:XX:XX:3E
- Field bus 2: XX:XX:XX:XX:XX:3F

5.5 Web server

The SDG has an integrated web server that can be accessed via the "Config" Ethernet RJ45 interface. On delivery, the SDG has a fixed, preset IP(v4) address:

- 192.168.1.10

The IP(v4) address can be changed via the "Settings" menu. Use of a dynamic IP address, assigned by DHCP, can also be configured.

Access to the web server is protected by password. The initial access data are as follows:

- Name: schmersal
- Password: schmersal

You must assign a new, secure password immediately after initial commissioning.

The web server has three areas:

Start screen/overview

This area displays important information about the system status of the gateway, which can be found on the left-hand side

- Hour meter
- Hardware and software version
- Ordering code and serial number
- Processor temperature
- Supply voltage level
- Field bus information
- SD bus configuration (number of devices taught in and found)
- SD card capacity

The central also shows a depiction of the system log. The SD card of the SDG can also be used to access the log file. The system log can only be written continuously if an SD card is inserted.

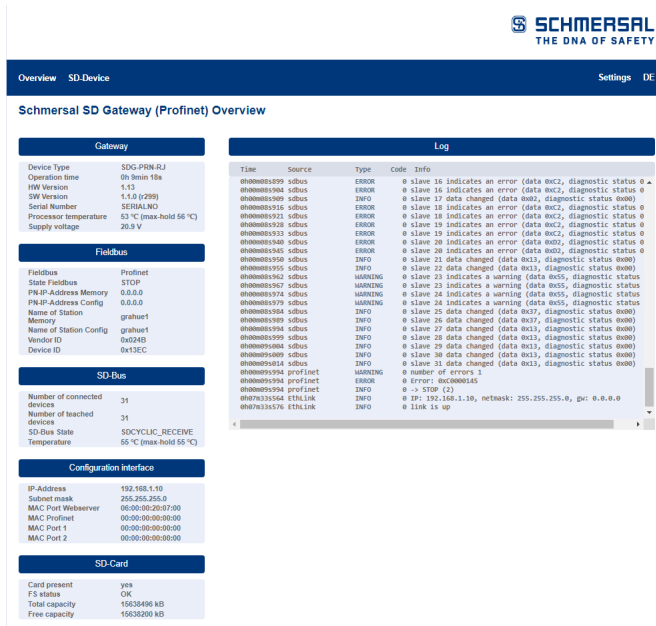

Figure 3: Web server start screen

SD devices

This area contains information on operation of the SD bus. The left-hand area contains information on signal quality. In addition, there is also the option to initiate the teach-in process and to control SD devices directly.

- **Field bus**
 - Type of field bus used
 - Detailed information about the SDG field bus device type (e.g. vendor and device ID)
 - Field bus connection status
- **SD bus status and statistics**
 - Number of previous switch-on operations
 - Hour meter
 - Status of the SD bus
 - Number of bytes sent/received
 - Number of data frames sent/received
 - Number of successful and failed repetitions
 - Number of checksum errors
 - Status of the SD bus
 - Active yes/no
 - Startup completed
 - Master in startup
 - Master error status
 - Communication error
 - Initialisation error
 - Short-circuit on SD bus
 - Teach-in required
- **Control SD device**
 - Device: selection of SD nodes to be addressed
 - Command: entry of request byte, hex-encoded
 - Execute: clicking on "Execute" sends the specified request byte to the selected SD node

If teach-in is required, the teach-in process can be triggered by pressing the "TEACH" button in the "SD bus status and statistics" area.

Schmersal SD Gateway (EtherCAT) SD-Devices



Figure 4: Detailed view of SD devices web server

Settings

The password and IPv4 address can be modified in this area.

- **Password**
 - To modify the password, enter the current password and the new password in the designated fields and confirm with "Execute". The new password will be queried when the web server is called up via the diagnostics interface after the next restart.
- **IP address**
 - Enter the desired IP address, subnet mask and gateway address.
 - If desired, the IP information can also be obtained via DHCP. In that case, select the corresponding checkbox. The settings are applied with "Execute".

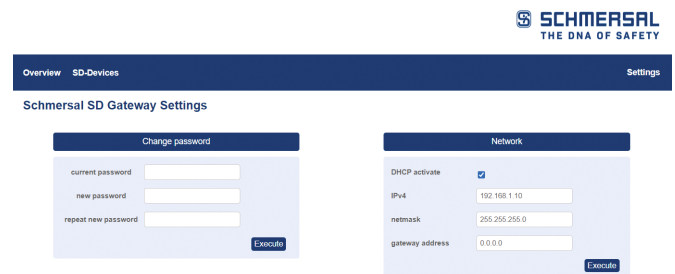

Figure 5: Settings

6. Operation of SD bus and communication

6.1 Teach-in of safety switchgear devices via SD interface

Teach-in of the SD chain is required on initial commissioning or in the event of a deviation between the saved and fixed configuration detected by the SD gateway (i.e. number, type and sequence of SD chain). The device indicates that teach-in was successful by flashing the "FUNC" LED. There are three different ways to initiate teach-in of an SD chain.

Option 1 - Configuration and diagnostics interface:

The teach-in process can be initiated via the web interface using the "TEACH" button on the "SD devices" screen.

Option 2 - "TEACH" button:

The teach-in process can be started by pressing and holding the "TEACH" button on the front panel of the SDG for 2 seconds.

Option 3 – Field bus:

The teach-in command can be initiated via field bus with an acyclic command. This requires the first byte of the invocation to have command 0x63 and the second byte the address of the gateway 0x00 (see Section 6.4, Table 4).

The teach-in process workflow is also outlined under "Teaching in SD chain" in Section 9.2.



To prevent operating errors, a tool (e.g. a pencil) is required to press the key button. Do not use objects that could cause a short-circuit on the circuit board.



The key button is located under the opening in the front panel. A light press is all that is required to press the key button. Excessive force on the key button or other components could damage the device.

6.2 Communication with external PLC via field bus

A gateway represents the data of a total of 32 SD devices (31 SD slaves + 1 SD master/SD gateway) on the field bus. The SD bus data are represented on the field bus by a total of 64 words for each 2 bytes. Of these, 32 words are input data and 32 words are output data. The output data represent the call-up commands to the respective SD bus nodes, the input data contain the respective responses. 64 byte input and output data are assigned on the field bus, irrespective of the number of safety switchgear devices actually taught in.

Integrating the SDG into field bus communication

The SDG is integrated into an existing field bus environment. This requires use of the corresponding field bus-specific device description file. This file can be downloaded from www.products.schmersal.com. The gateway's field bus communication requires a functioning field bus master.

The gateway always represents the maximum of devices and/or their data, irrespective of the number of safety switchgear devices that have been taught in. The output data (1 WORD = 2 bytes, or 1 byte) correspond to the request byte, the output data (always 1 complete WORD = 2 bytes) to the status byte and to the diagnostics byte (warning or error, cf. Section 6.2). Data sorting in the field bus environment is aligned with the sequence of the devices in the physical installation, i.e. the input and output data of the first device in the series wiring are shown as the first element on the field bus.

Safety switchgear devices with SD interface can be controlled via the respective request byte or the WORD of the field bus output data. This allows, e.g. the bolting device of interlocks to be locked or the LEDs of the illuminated control push button of control panels to be switched.

Table 3: Example cyclical SD data, AZM300

Bit index	Request byte	Response byte	Diagnostic error warning	Diagnostic error
0	Magnet on, irrespective of power to lock or power to unlock principle	Safety output activated	Error output Y1	Error output Y1
1	-	Safety guard closed AND locking/unlocking possible	Error output Y2	Error output Y2
2	-	Actuator detected and locked	Cross-wire short	Cross-wire short
3	-	-	Temperature too high	Temperature too high
4	-	Input condition X1 and X2	-	Incorrect or defective actuator, bracket broken
5	-	Valid actuator detected	Internal device error	Internal device error
6	-	Error warning	Communication error between the field bus Gateway and the safety switchgear	-
7	Error reset	Error (enabling path switched off)	Rotary handle not in authorised intermediate position	Rotary handle not in authorised intermediate position

6.3 Cyclical communication

While operational, there is cyclical communication on the SD bus, the content of which is transmitted cyclically on the field bus. Each SD bus node has one word of output data, request byte 00 and request byte 01 (unused in the case of SD slaves), and a word of input data, comprising a response byte and diagnostics byte (SD gateway response byte 00, see Table 6, response of last acyclic command, response byte 01 SD gateway, see Table 4)

6.4 Acyclic communication and individual activation of SD devices

In addition to cyclic communication, there is also the option to call up targeted SD bus nodes with acyclic communication, which then execute the corresponding commands. The specific response is then found in response byte 01 of the gateway

Via field bus

The option of acyclic communication is available with an active field bus.

A fixed process can be used to request acyclic data from the individual SD slaves via the 2 request bytes (field bus request byte 00 and byte 01) and the data byte (field bus response byte 01) (see table 4). The command byte is used to determine which data should be requested from a slave. The SD address byte is used to define the SD device from which the data is requested in the SD interface. The response data of the SD slave is then saved in the field bus response byte 01.

The process for requesting data is determined as follows:

1. The control deletes the data byte before and after each order.
Feedback is received via the response byte, indicating whether or not the data was deleted:
0xFF: data deleted, acyclic data service ready.
2. The control first writes the SD address to field bus request byte 01.
The control then writes the command byte to field bus request byte 00.
3. The response data is made available to the control in field bus response byte 01.
The data byte may also contain an error message as the response:
0xFE: Command error, non-defined command invoked.
0xFD: Address error, invalid slave address for selected command or slave address of an unavailable SD slave selected.

Individual diagnostics via web server

Without an active field bus, individual devices can be individually activated via the web server under "SD Devices" in "Direct control SD-Device". For this, the corresponding command (see documentation for SD devices, e.g. AZM300, I/O data and diagnosis data - invocation byte) must be entered and the destination address selected. The command is executed when the "Execute" button is pressed.

Table 4: Command overview and response data of acyclic communication

Commands Acyclic data query	Command byte Field bus byte 00 (Request)	SD address Field bus byte 01 (Request)	Data byte Field bus byte 01 (Response)	Data description
Delete data byte	0x00	-	0xFF	Data deleted, ready for new command
Read number of projected SD slaves	0x01	0x00	0x01 ... 0x1F	Number of projected slaves, 1 to 31
Read device category of an SD slave	0x02	0x01 ... 0x1F	0x30 ... 0xF8	Device category of addressed SD slaves, see Table 5
Read hardware revision of an SD slave	0x03	0x01 ... 0x1F	0x41 ... 0x5A	Hardware revision A - Z as ASCII characters
Read hardware revision of SDG	0x03	0x00	0x01 ... 0x63	Hardware revision 1...99 (major version/pre-decimal position of the SW version)
Read software version of SD device, high byte (SDG and slaves)	0x04	0x00 ... 0x1F	0x00 ... 0x63	Software version high byte 0...99 (major version/pre-decimal position corresponds to the hardware revision)
Read software version of SD device, low byte (SDG and slaves)	0x05	0x00 ... 0x1F	0x00 ... 0x63	Software version low byte 0...99 major version/pre-decimal position corresponds to the hardware revision
Read the number of SD slaves actually available	0x06	0x00	0x00 ... 0x1F	Number of slaves found, 0 to 31
Read byte 0 of the SD slave serial number	0x07	0x01 ... 0x1F	0x30 ... 0x39 0x41 ... 0x5A	0...9 ASCII A...Z ASCII
Read byte 1 of the SD slave serial number	0x08	0x01 ... 0x1F	0x30 ... 0x39 0x41 ... 0x5A	0...9 ASCII A...Z ASCII
Read byte 2 of the SD slave serial number	0x09	0x01 ... 0x1F	0x30 ... 0x39 0x41 ... 0x5A	0...9 ASCII A...Z ASCII
Read byte 3 of the SD slave serial number	0x0A	0x01 ... 0x1F	0x30 ... 0x39 0x41 ... 0x5A	0...9 ASCII A...Z ASCII
Read byte 4 of the SD slave serial number	0x0B	0x01 ... 0x1F	0x30 ... 0x39 0x41 ... 0x5A	0...9 ASCII A...Z ASCII
Teach-in of found SD chain (teach-in)	0x63	0x00	0x00	SD chain was taught in again

To automatically identify the SD chain, the device category of all connected SD slaves can be read out via field bus (see also Command overview and response data, acyclic communication).

Table 5: SD device categories

Equipment category	Description
0x30	CSS 34, Safety sensor
0x31	AZM 200, Solenoid interlock "Z" version
0x32	MZM 100, Solenoid interlock "Z" version
0x33	AZ 200, Safety switch
0x34	CSS 30S, Safety sensor
0x35	MZM 100 B, Solenoid interlock "B" version
0x36	AZM 300B, Solenoid interlock "B" version
0x37	RSS 36, Safety sensor
0x38	AZM 300Z, Solenoid interlock "Z" version
0x39	RSS 16, Safety sensor
0x3A	RSS 260, Safety sensor
0x3D	MZM 120 B, Solenoid interlock "B" version
0x3E	MZM 120 BM, Solenoid interlock "B" version
0x3F	AZM 201Z, Solenoid interlock "Z" version
0x40	AZM 201B, Solenoid interlock "B" version
0x41	BDF200, control panel
0x43	AZ 201, Safety switch

Table 6: SDG master diagnostics data and system errors, response byte node 0x00

Bit	Condition	Description
0	SD interface fault	Collective fault message, message 1 sec. delayed, SD data no longer valid
1	-	
2	-	
3	-	
4	SD initialisation error	Re-initialisation of SD chain required Switch supply voltage to SD master and connected devices off and on again. There may be no connected SD slaves.
5	SD teach error	Structure of SD chain differs from saved configuration. Confirm with teach-in again.
6	SD-Short-circuit	Short-circuit to SD cables. Remove power and rectify errors.
7	SD communication error	One or more SD slaves cannot be contacted. SD slave data no longer valid. Check SD installation for errors.

7. Wiring example

7.1 Series wiring evaluation

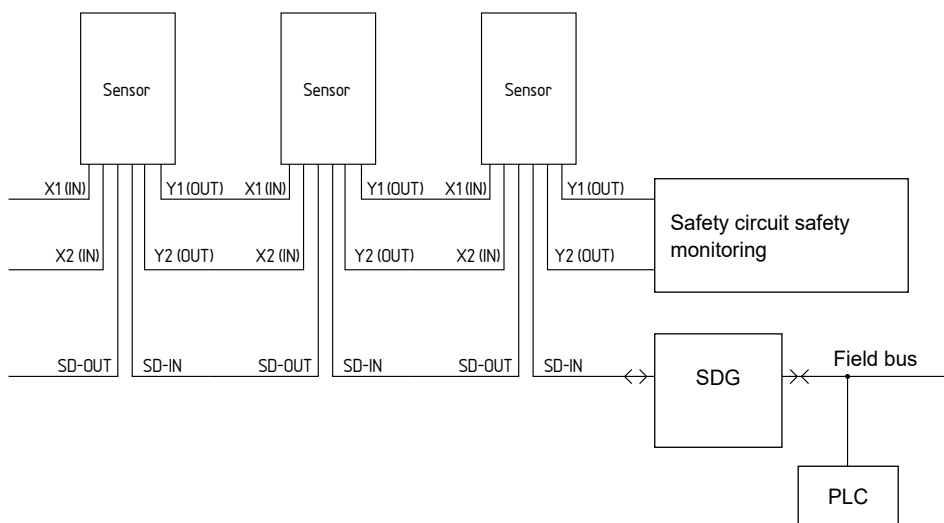



Accessories for the series-wiring

For convenient wiring and series wiring of SD components, the Y distributor CSS-Y-8P, passive field box PFB-SD-4M12-SD (variant for the field) and the control cabinet distributor module PDM-SD-4CC-SD (variant for control cabinet on carrier rail) are available along with additional comprehensive accessories. More information can be found in our online catalogue at products.schmersal.com.

8. Diagnostic

8.1 LED indications

For a description of the LED indicators, see Table 2 in Section 5.3.

8.2 Faults

Faults and fault causes are indicated by the corresponding status of the ERR LED. For a description of the LED indicators, see Table 2 in Section 5.3.

9. Set-up and maintenance

9.1 Commissioning

The field bus gateway is intended for assembly in a control cabinet with IP54 degree of protection.

The field bus gateway is delivered ready for operation.

9.2 SDG commissioning

If a continuous (i.e. still available and shutdown and reactivation) configuration and system log are required, a micro SD card with sufficient storage capacity (recommended >4 GB) must be inserted into the SDG's card slot before commissioning.

Teaching in the SD chain

Start by connecting the SDG to an existing SD chain — the SD devices must be de-energised to start with. The device and SD nodes must be connected to the power supply (24 V/DC, 0 V, FE) for commissioning. The device starts up, identifiable by the LEDs lighting up (see also Section 5.3). The system should be ready for operation approx. 30 seconds after switch-on — use the LED indicators to check. If this is initial commissioning, teach-in of the connected SD chain is required. Teach-in is required if there are any changes to the SD chain (e.g. replacement, removal or addition of devices). The need to teach in is indicated by a flashing FUNC LED. Teach-in can be initiated by pressing and holding the "TEACH" key button on the front of the gateway (see Fig. 2) for two seconds, via the web interface or via field bus. The process may last a few seconds. When teach-in is successful, the "FUNC" LED goes out. Details of the connected SD chain can now be viewed via the web server (SD Devices area).

Viewing the SD chain

Pressing the "TEACH" key button on the front panel of the gateway twice (maximum interval 1 s) displays the actual number of SD devices connected to the gateway by a flash of the green FUNC LED. Pressing the "TEACH" key button on the front panel of the gateway three times (maximum interval 1 s) displays the number of SD devices that have been taught in by a flash of the yellow FUNC LED.

9.3 Functional testing

The function of the field bus must be tested.

The following conditions must be previously checked and met:

1. Correct fixing
2. Check the integrity of the cable entry and connections
3. Check field bus gateway enclosure for damage
4. Check the electrical function of the connected sensors and their influence on the field bus gateway and downstream actuators

9.4 Behaviour in the case of faults

In the event of a fault the following procedure is recommended:

1. Identify errors according to flash codes from Section 8.2.
 2. Rectify the fault if it is described in the table.
 3. Switch operating voltage off and on and erase fault mode.
- If fault could not be rectified, please contact the manufacturer.

Reset to factory settings

Pressing and holding the TEACH key button for 5 s without connected SD chain resets the device to factory settings, i.e.

- The list of taught-in devices
 - The network settings
 - The password
- are reset to the as-delivered condition. In addition
- The log file is deleted
 - The SD card is formatted
 - The switch-on counter is reset

The RUN LED flashes green and red alternately while the rest is in progress.

10. Disassembly and disposal

10.1 Disassembly

The field bus gateway must be disassembled in a de-energised condition only.

10.2 Disposal

The field bus gateway must be disposed of in an appropriate manner in accordance with the national prescriptions and legislations.

11. EU Declaration of conformity

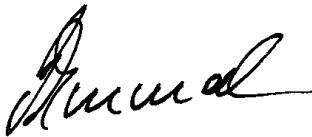
EU Declaration of conformity		
Original	K.A. Schmersal GmbH & Co. KG Möddinghofe 30 42279 Wuppertal Germany Internet: www.schmersal.com	
We hereby certify that the hereafter described components both in their basic design and construction conform to the applicable European Directives.		
Name of the component:	SDG	
Type:	see ordering code	
Description of the component:	Field bus gateway for serial diagnostics	
Relevant Directives:	EMC-Directive RoHS-Directive	2014/30/EU 2011/65/EU
Applied standards:	EN 61131-2:2007 IEC 61131-2:2017	
Person authorised for the compilation of the technical documentation:	Oliver Wacker Möddinghofe 30 42279 Wuppertal	
Place and date of issue:	Wuppertal, November 6, 2023	
		
	Authorised signature Philip Schmersal Managing Director	

SDG-A-EN



The currently valid declaration of conformity can be downloaded from the internet at products.schmersal.com.

