



**EN** Operating instructions. . . . .pages 1 to 6  
Original

**Content**

**1 About this document**

1.1 Function . . . . . 1

1.2 Target group: authorised qualified personnel. . . . . 1

1.3 Explanation of the symbols used . . . . . 1

1.4 Appropriate use . . . . . 1

1.5 General safety instructions . . . . . 1

1.6 Warning about misuse . . . . . 2

1.7 Exclusion of liability . . . . . 2

**2 Product description**

2.1 Ordering code . . . . . 2

2.2 Special versions. . . . . 2

2.3 Purpose . . . . . 2

2.4 Technical data . . . . . 2

2.5 Derating / electrical lifespan of safety contacts . . . . . 3

2.6 Safety classification . . . . . 3

**3 Mounting**

3.1 General mounting instructions . . . . . 3

3.2 Dimensions . . . . . 3

**4 Electrical connection**

4.1 General information for electrical connection. . . . . 3

**5 Operating principle and settings**

5.1 LED functions. . . . . 3

5.2 Description of the terminals . . . . . 3

**6 Set-up and maintenance**

6.1 Commissioning . . . . . 4

6.2 Functional testing. . . . . 4

6.3 Maintenance . . . . . 4

**7 Disassembly and disposal**

7.1 Disassembly. . . . . 4

7.2 Disposal . . . . . 4

**8 Appendix**

8.1 Wiring examples . . . . . 4

**9 EU Declaration of conformity**

**1. About this document**

**1.1 Function**  
This operating instructions manual provides all the information you need for the mounting, set-up and commissioning to ensure the safe operation and disassembly of the safety-monitoring module. The operating instructions must be available in a legible condition and a complete version in the vicinity of the device.

**1.2 Target group: authorised qualified personnel**  
All operations described in this operating instructions manual must be carried out by trained specialist personnel, authorised by the plant operator only.

Please make sure that you have read and understood these operating instructions and that you know all applicable legislations regarding occupational safety and accident prevention prior to installation and putting the component into operation.

The machine builder must carefully select the harmonised standards to be complied with as well as other technical specifications for the selection, mounting and integration of the components.

**1.3 Explanation of the symbols used**

 **Information, hint, note:**  
This symbol indicates useful additional information.

 **Caution:** Failure to comply with this warning notice could lead to failures or malfunctions.  
**Warning:** Failure to comply with this warning notice could lead to physical injury and/or damage to the machine.

**1.4 Appropriate use**  
Products in Schmersal's range are not intended to be used by private end consumers.

The products described in these operating instructions are developed to execute safety-related functions as part of an entire plant or machine. It is the responsibility of the manufacturer of a machine or plant to ensure the correct functionality of the entire machine or plant.

The output expander module must be exclusively used in accordance with the versions listed below or for the applications authorised by the manufacturer. Detailed information regarding the range of applications can be found in the chapter "Product description".

**1.5 General safety instructions**  
The user must observe the safety instructions in this operating instructions manual, the country specific installation standards as well as all prevailing safety regulations and accident prevention rules.

 Further technical information can be found in the Schmersal catalogues or in the online catalogue on the Internet: [products.schmersal.com](http://products.schmersal.com).

The information contained in this operating instructions manual is provided without liability and is subject to technical modifications.

There are no residual risks, provided that the safety instructions as well as the instructions regarding mounting, commissioning, operation and maintenance are observed.

### 1.6 Warning about misuse



In case of inadequate or improper use or manipulations of the component, personal hazards or damage to machinery or plant components cannot be excluded.

### 1.7 Exclusion of liability

We shall accept no liability for damages and malfunctions resulting from defective mounting or failure to comply with this operating instructions manual. The manufacturer shall accept no liability for damages resulting from the use of unauthorised spare parts or accessories.

For safety reasons, invasive work on the device as well as arbitrary repairs, conversions and modifications to the device are strictly forbidden, the manufacturer shall accept no liability for damages resulting from such invasive work, arbitrary repairs, conversions and/or modifications to the device.

## 2. Product description

### 2.1 Ordering code

This operating instructions manual applies to the following types:

#### SRB-E-602EM<sup>①</sup>

No.	Option	Description
①	-CC	plug-in screw terminals 0.25...2.5 mm <sup>2</sup> plug-in cage clamps 0.25 ... 1.5 mm <sup>2</sup>

### 2.2 Special versions

For special versions, which are not listed in the order code below 2.1, these specifications apply accordingly, provided that they correspond to the standard version.

### 2.3 Purpose

The output expander modules for integration in safety circuits are designed for fitting in control cabinets. They are used for the safe evaluation of the signals and the safe contact multiplication of an upstream safety-monitoring module.

The safety function is only realised in conjunction with the basic device. To this effect, the device must be connected in accordance with the wiring example.

The SRB-E-602EM output expander module can be controlled with one or two basic devices. Either 1 x 6 or 2 x 3 safe output contacts are then available.

The function is defined as the opening of the enabling circuits 13-14, 23-24, 33-34 and 53-54, 63-64, 73-74 when the supply voltage A1-A2 / A1.1-A2.1 is disconnected. The safety-relevant current paths with the outputs contacts 13-14, 23-24, 33-34 and 53-54, 63-64, 73-74 meet the following requirements under observation of a PFH value assessment (also refer to chapter 2.6 "Safety classification"):

- Control category 4 – PL e to ISO 13849-1
- SIL 3 to IEC 61508
- SIL CL 3 to EN 62061

To determine the Performance Level (PL) to EN ISO 13849-1 of the entire safety function (e.g. sensor, logic, actuator), an assessment of all relevant components is required.



The entire concept of the control system, in which the safety component is integrated, must be validated to the relevant standards.

### 2.4 Technical data

#### General data:

Standards:	EN 60204-1, EN 60947-5-1, EN ISO 13849-1, IEC 61508
Climate resistance:	EN 60068-2-78
Mounting:	Snaps onto standard rail to EN 60715
Terminal designations:	EN 60947-1
Material of the housings:	Plastic, glass-fibre reinforced thermoplastic, ventilated
Weight:	215 g
Start conditions:	Automatic
Feedback circuit (Y/N):	yes
Pull-in delay:	typ. 20 / max. 35 ms
Drop-out delay:	typ. 25 / max. 35 ms

#### Mechanical data:

Connection type:	refer to 2.1 Ordering code
Cable section:	refer to 2.1 Ordering code
Connecting cable:	rigid or flexible
Tightening torque for the terminals:	0.5 Nm
With removable terminals (Y/N):	yes
Mechanical life:	10 million operations
Electrical life:	refer to 2.5
Resistance to shock:	20 g / 11 ms
Resistance to vibration in accordance with EN 60068-2-6:	10 ... 55 Hz, amplitude 0.35 mm

#### Ambient conditions:

Ambient temperature:	-25 °C ... +60 °C
Storage and transport temperature:	-40 °C ... +85 °C
Degree of protection:	Enclosure: IP40 Terminals: IP20 Clearance: IP54
Air clearances and creepage distances to EN 60664-1:	4 kV/2 (basic insulation)
EMC rating:	to EMC Directive

#### Electrical data:

Contact resistance in new state:	max. 100 mΩ
Power consumption:	max. 2.9 W / 4.9 VA
Rated operating voltage $U_e$ :	24 VDC -15% / +20%, residual ripple max. 10%, 24 VAC -15% / +10%
Frequency range:	50 / 60 Hz
Max. fuse rating of the operating voltage:	F1, F2: T 1.0 A / 250 V

#### Inputs:

Wire breakage detection (Y/N):	Yes
Earth leakage detection (Y/N):	Yes
Conduction resistance:	max. 40 Ω

#### Relay outputs:

Number of safety contacts:	6
Number of auxiliary contacts:	2
Switching capacity of the safety contacts:	13-14, 23-24, 33-34; 53-54, 63-64, 73-74: max. 250 V, 6 A ohmic (inductive in case of appropriate protective wiring), min. 10 V / 10 mA
Switching capacity of the auxiliary contacts:	41-42, 81-82: 24 VDC / 2 A
Fuse rating of the safety contacts:	external ( $I_k = 1000$ A) to EN 60947-5-1 Safety fuse 10 A quick blow, 6 A slow blow
Fuse rating for the auxiliary contacts:	external ( $I_k = 1000$ A) to EN 60947-5-1 Safety fuse 2.5 A quick blow, 2 A slow blow
Utilisation category to EN 60947-5-1:	AC-15: 230 VAC / 4 A DC-13: 24 VDC / 4 A
Safety contact values:	resistance max. 100 mΩ, AgNi, self-cleaning, positive action
Max. switching cycles / minute:	20
Inductive consumers:	Provision should be made for a suitable protection circuit.

The data specified in this manual are applicable when the component is operated with rated operating voltage  $U_e \pm 0\%$ .



The wire insulation for the field-wiring are going to be minimum 90°C.  
Field wiring terminals to use copper conductors only, minimum temperature rating 60/75°C.

### 2.5 Derating / electrical lifespan of safety contacts

No derating with individual installation of safety-monitoring modules.

Derating on request if several modules are installed one after the other without spacing and with maximum output load and ambient temperatures.

#### Electrical life of the safety contacts

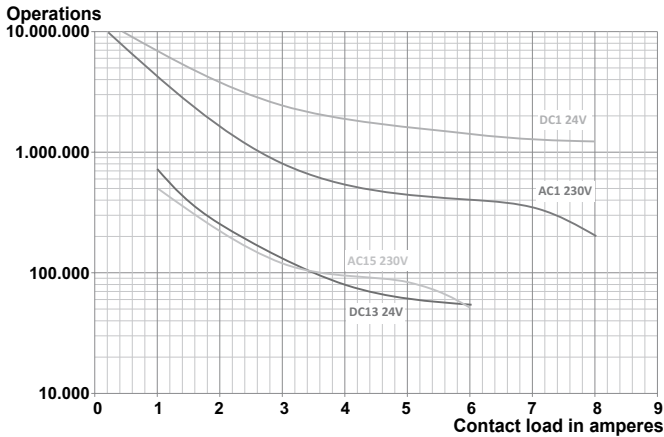

### 2.6 Safety classification

Standards:	EN ISO 13849-1, IEC 61508
PL:	up to e
Control category:	up to 4
DC:	99% (high)
CCF:	> 65 points
PFH value:	$\leq 2.0 \times 10^{-8}/h$
SIL:	up to 3
Mission time:	20 years

The PFH value applies to the combinations of contact load (current through enabling contacts) and number of switching cycles (nop/y) mentioned in the table below. At 365 operating days per year and a 24-hours operation, this results in the below-mentioned switching cycle times ( $t_{cycle}$ ) for the relay contacts.

Contact load	$n_{op/y}$	$t_{cycle}$
20 %	525,600	1.0 min
40 %	210,240	2.5 min
60 %	75,087	7.0 min
80 %	30,918	17.0 min
100 %	12,223	43.0 min

Diverging applications upon request.

## 3. Mounting

### 3.1 General mounting instructions

Mounting: snaps onto standard rails to EN 60715.

Snap the bottom of the enclosure slightly tilted forwards in the standard rail and push up until it latches in position.

The output expander module is to be operated in an area in which access by personnel is restricted.

### 3.2 Dimensions

Device dimensions (H/W/D): 98 x 22.5 x 115 mm

## 4. Electrical connection

### 4.1 General information for electrical connection



The electrical connection may only be carried out by authorised personnel in a de-energised condition.



As far as the electrical safety is concerned, the protection against unintentional contact of the connected and therefore electrically interconnected apparatus and the insulation of the feed cables must be designed for the highest voltage, which can occur in the device.



To avoid EMC disturbances, the physical ambient and operational conditions at the place where the product is installed, must meet the provisions laid down in the paragraph "Electromagnetic Compatibility (EMC)" of EN 60204-1.

#### Settle length x of the conductor:

- on screw terminals: 7 mm
- on cage clamps of type s or f: 10 mm



Wiring examples: see appendix

## 5. Operating principle and settings

### 5.1 LED functions

- K1/K2: status channels 1 and 2
- K3/K4: status channels 3 and 4

### 5.2 Description of the terminals

Voltages:	A1 / A1.1	+24 VDC / 24 VAC
	A2 / A2.1	0 VDC / 0 VAC
Outputs Module 1:	13-14	1. safety contact
	23-24	2. safety contact
	33-34	3. safety contact
	41-42	Signalling contact (NC)
Feedback circuit 1:	X1-X2	NC contacts (monitoring by basic module!)
Outputs Module 2:	53-54	4. safety contact
	63-64	5. safety contact
	73-74	6. safety contact
	81-82	Signalling contact (NC)
Feedback circuit 2:	X3-X4	NC contacts (monitoring by basic module!)



Signalling contacts must not be used in safety circuits.

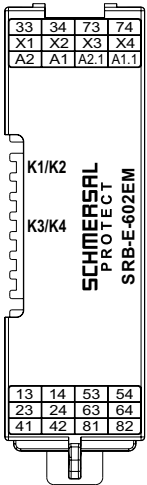

Fig. 1

**Internal wiring diagram:**

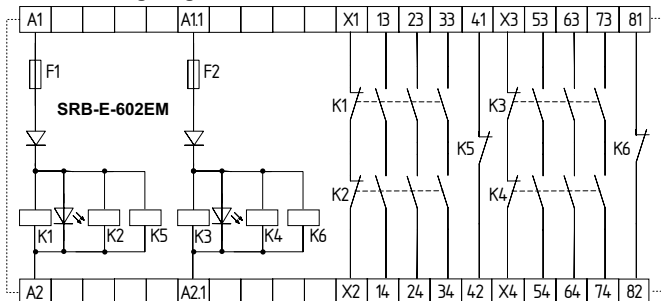

Fig. 2

**6. Set-up and maintenance**

**6.1 Commissioning**

The output extension is intended for assembly in a switch cabinet with degree of protection IP54.

**6.2 Functional testing**

The function of the output expander module must be tested. The following conditions must be previously checked and met:

1. Correct fixing
2. Check the integrity of the cable entry and connections
3. Check the output expander module's enclosure for damage.

**6.3 Maintenance**

A regular visual inspection and functional test, including the following steps, is recommended:

1. Check the correct fixing of the output expander module
2. Check the cable for damages
3. Check electrical function



If a manual functional check is necessary to detect a possible accumulation of faults, then this must take place during the intervals noted as follows:

- at least every month for PL e with category 3 or category 4 (according to EN ISO 13849-1) or SIL 3 with HFT (hardware fault tolerance) = 1 (according to EN 62061);
- at least every 12 months for PL d with category 3 (according to EN ISO 13849-1) or SIL 2 with HFT (hardware fault tolerance) = 1 (according to EN 62061).

**Damaged or defective components must be replaced.**

**7. Disassembly and disposal**

**7.1 Disassembly**

The output expander module must be disassembled in the de-energised condition only.

Push up the bottom of the enclosure and hang out slightly tilted forwards.

**7.2 Disposal**

The output expander module must be disposed of in an appropriate manner in accordance with the national prescriptions and legislations.

**8. Appendix**

**8.1 Wiring examples**

**Single-channel control with a basic device for contact duplication with 1 x 6 safety contacts.**

It is controlled by a safety contact or safety output of the basic module (see Fig. 3.1)

- Connections X1/X2 and X3/X4 of the expansion module must be connected in series to the feedback circuit or pushbutton circuit of the basic module.



With this application, a fault to 24 V potential in the cable routing must be ruled out.

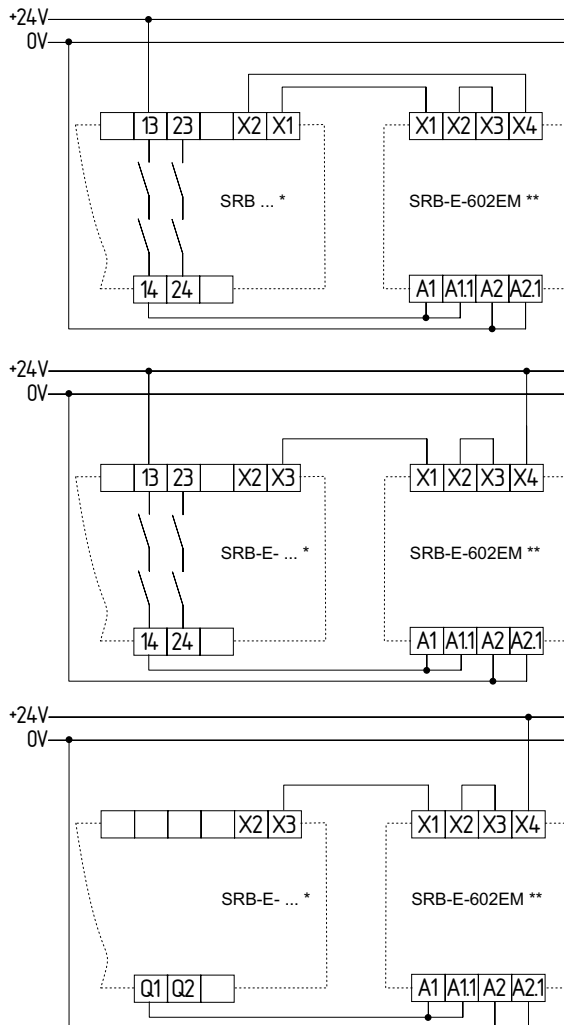

Fig. 3.1 \* = basic module; \*\* = expander module

**Single-channel control with two basic devices for contact duplication with 2 x 3 safety contacts.**

It is controlled by a safety contact or safety output of the basic module (see Fig. 3.2)

- Connections X1/X2 and X3/X4 of the expansion module must be connected in series to the feedback circuit or pushbutton circuit of the basic module.

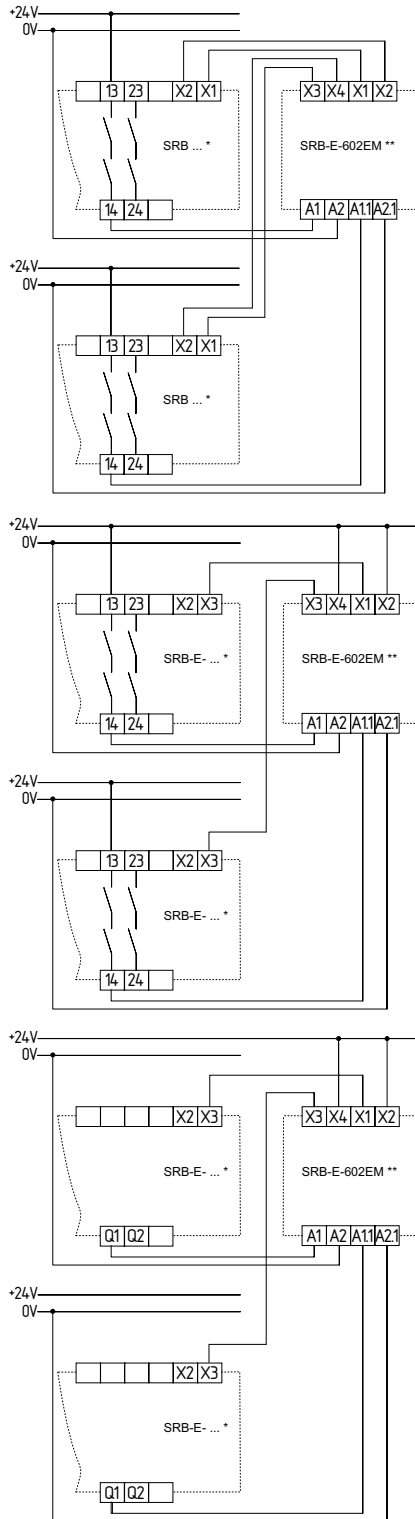

Fig. 3.2 \* = basic module; \*\* = expander module

**Two-channel control with a basic device for contact duplication with 1 x 6 safety contacts.**

Control is via two safety contacts of the basic module (see Fig. 4)

- Connections X1/X2 and X3/X4 of the expansion module must be connected in series to the feedback circuit or pushbutton circuit of the basic module.

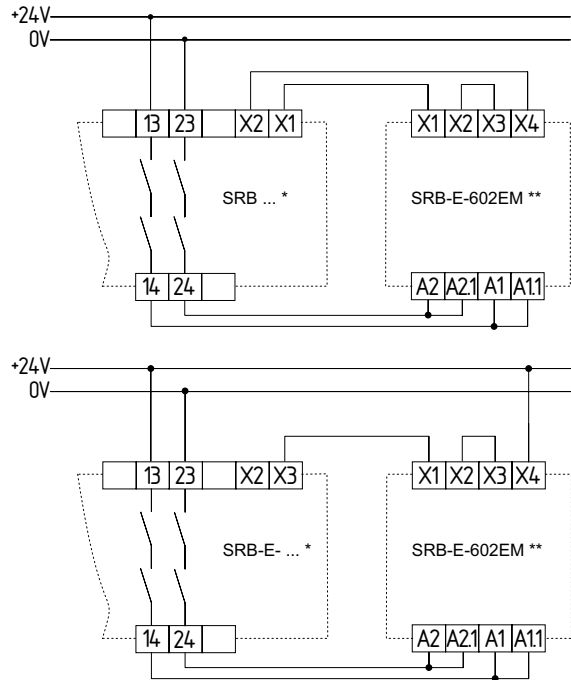

Fig. 4 \* = basic module; \*\* = expander module



The expander module must be wired in accordance with the wiring example. The safety function is only realised in conjunction with the basic device.



Example. The terminal designation of the basic module can deviate depending on the used type, please also observe the description of the basic module.

9. EU Declaration of conformity

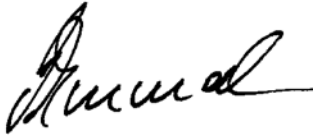
EU Declaration of conformity		 <b>SCHMERSAL</b>
Original	K.A. Schmersal GmbH & Co. KG Möddinghofe 30 42279 Wuppertal Germany Internet: www.schmersal.com	
We hereby certify that the hereafter described components both in their basic design and construction conform to the applicable European Directives.		
<b>Name of the component:</b>	SRB-E-602EM	
<b>Type:</b>	See ordering code	
<b>Description of the component:</b>	Contact expander module This device has no internal logic and must only be used as output expander in conjunction with a basic component, which is suitable for the application.	
<b>Relevant Directives:</b>	Low Voltage Directive	2014/35/EU
	EMC-Directive	2014/30/EU
	RoHS-Directive	2011/65/EU
<b>Applied standards:</b>	EN 60947-5-1:2017	
<b>Person authorised for the compilation of the technical documentation:</b>	Oliver Wacker Möddinghofe 30 42279 Wuppertal	
<b>Place and date of issue:</b>	Wuppertal, March 15, 2022	
SRB-E-602EM-A-EN		
	Authorised signature <b>Philip Schmersal</b> Managing Director	



The currently valid declaration of conformity can be downloaded from the internet at [products.schmersal.com](http://products.schmersal.com).

