



EN Operating instructions.pages 1 to 6
Original

Content

1 About this document
 1.1 Function 1
 1.2 Target group: authorised qualified personnel. 1
 1.3 Explanation of the symbols used 1
 1.4 Appropriate use 1
 1.5 General safety instructions 1
 1.6 Warning about misuse 1
 1.7 Exclusion of liability 1

2 Product description
 2.1 Ordering code 2
 2.2 Special versions. 2
 2.3 Purpose and use 2
 2.4 Technical data 3
 2.5 Safety classification 3

3 Mounting
 3.1 General mounting instructions 4
 3.2 Dimensions 4

4 Electrical connection
 4.1 General information for electrical connection. 4
 4.2 Cable 5
 4.3 Contact variants. 5

5 Set-up and maintenance
 5.1 Functional testing. 6
 5.2 Maintenance 6

6 Disassembly and disposal
 6.1 Disassembly. 6
 6.2 Disposal 6

7 Declaration of conformity

1. About this document

1.1 Function

This operating instructions manual provides all the information you need for the mounting, set-up and commissioning to ensure the safe operation and disassembly of the safety switchgear. The operating instructions must be available in a legible condition and a complete version in the vicinity of the device.

1.2 Target group: authorised qualified personnel

All operations described in this operating instructions manual must be carried out by trained specialist personnel, authorised by the plant operator only.

Please make sure that you have read and understood these operating instructions and that you know all applicable legislations regarding occupational safety and accident prevention prior to installation and putting the component into operation.

The machine builder must carefully select the harmonised standards to be complied with as well as other technical specifications for the selection, mounting and integration of the components.

1.3 Explanation of the symbols used



Information, hint, note:

This symbol is used for identifying useful additional information.



Caution: Failure to comply with this warning notice could lead to failures or malfunctions.

Warning: Failure to comply with this warning notice could lead to physical injury and/or damage to the machine.

1.4 Appropriate use

The Schmersal range of products is not intended for private consumers.

The products described in these operating instructions are developed to execute safety-related functions as part of an entire plant or machine. It is the responsibility of the manufacturer of a machine or plant to ensure the correct functionality of the entire machine or plant.

The safety switchgear must be exclusively used in accordance with the versions listed below or for the applications authorised by the manufacturer. Detailed information regarding the range of applications can be found in the chapter "Product description".

1.5 General safety instructions

The user must observe the safety instructions in this operating instructions manual, the country specific installation standards as well as all prevailing safety regulations and accident prevention rules.



Further technical information can be found in the Schmersal catalogues or in the online catalogue on the Internet: products.schmersal.com.

The information contained in this operating instructions manual is provided without liability and is subject to technical modifications.

There are no residual risks, provided that the safety instructions as well as the instructions regarding mounting, commissioning, operation and maintenance are observed.

1.6 Warning about misuse



In case of improper use or manipulation of the safety switchgear, personal hazards or damages to machinery or plant components cannot be excluded.

1.7 Exclusion of liability

We shall accept no liability for damages and malfunctions resulting from defective mounting or failure to comply with this operating instructions manual. The manufacturer shall accept no liability for damages resulting from the use of unauthorised spare parts or accessories.

For safety reasons, invasive work on the device as well as arbitrary repairs, conversions and modifications to the device are strictly forbidden, the manufacturer shall accept no liability for damages resulting from such invasive work, arbitrary repairs, conversions and/or modifications to the device.

2. Product description

2.1 Ordering code

This operating instructions manual applies to the following types:

TZ①②③④⑤24VDC-⑥

No.	Option	Description	
①	M	Power to lock	
	F	Power to unlock	
②	Contact variants (also refer to 4.3)		
	Magnet		
	Actuator		
		1 NC	1 NC / 1 NO
	W	1 NC	1 NC / 1 NO
	C	1 NC / 1 NO	1 NC / 1 NO
	CW	1 NC / 1 NO	1 NC / 1 NO
	3OE/1S	1 NC	2 NC / 1 NO
	W3OE	1 NC	2 NC / 1 NO
	4OE	2 NC	2 NC
W2MOE	2 NC	1 NC / 1 NO	
③	N	Emergency release N	
	.NE	Manual release .NE	
	.NEM	Manual release .NEM	
	S	Manual release using triangular key	
	SP	Manual release with triangular key and release bar	
	S.NF	Emergency exit and manual release with LED display	
④	L	Actuating head higher and rotated 180°	
⑤	.CHI	Actuating head higher and rotated 180°	
⑥	3053	Customer-specific contact variant	

Not all component variants, which are possible according to this order code, are available.



The device variants .N, .NE and .NEM mentioned in the order code under 2.1. are not consistent with test principle BG-GS-ET-19.



Only if the information described in this operating instructions manual are realised correctly, the safety function and therefore the compliance with the Machinery Directive is maintained.

2.2 Special versions

For special versions, which are not listed in the order code below 2.1, these specifications apply accordingly, provided that they correspond to the standard version.

2.3 Purpose and use

The solenoid interlock has been designed to prevent in conjunction with the control part of a machine, movable safety guards from being opened before hazardous conditions have been eliminated.



Interlocks with power to lock principle may only be used in special cases after a thorough evaluation of the accident risk, since the guarding device can immediately be opened on failure of the electrical power supply or when the main switch is opened.



The safety switchgears are classified according to EN ISO 14119 as type 2 interlocking devices.

Manual release TZF..S (for set-up, maintenance, etc.)

The manual release is realised by turning the triangular key (included in delivery) to the right (1), so that the locking bolt is pulled into the release position. The normal locking function is only restored after the triangular key has been returned to its original position (2). The manual release must be sealed after being put into operation (e.g. sealant etc.) to prevent its utilisation during operation. The manual release must not be actuated when loaded by the safety guard.

Manual release TZF..SP (for set-up, maintenance, etc.)

The manual release is realised by turning the triangular key (included in delivery) to the left (1) and by pulling simultaneously the release bar (2), so that the locking bolt is pulled into the release position. After the triangular key (1) has been turned back to the left, the release bar (2) returns to its position and the normal locking function is restored. The manual release must be sealed after being put into operation (e.g. sealant etc.) to prevent its utilisation during operation. The manual release must not be actuated when loaded by the safety guard.

Manual release TZF..S

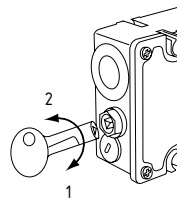

Manual release TZF..SP

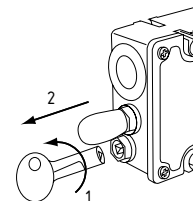

Emergency release TZFN

(mounting only on the outside of the safety guard)

To realise an emergency release, the release button (1) must be pulled. The release button latches. In this position, the safety guard can be opened. To neutralise the blocked condition, use the triangular key (2) (included in delivery) to turn the triangular screw to the left until the release button returns to its original position. The released condition may only be cancelled by an authorised person. The emergency release must not be used when the machinery/plant is in operation.

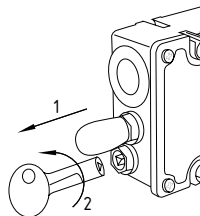

The emergency release must be clearly labelled that it should only be used in an emergency. The label can be used that was included in the delivery. The solenoid interlock should be installed and/or protected so that an inadvertent opening of the interlock by an emergency release can be prevented.

Manual release TZF...NE / TZF...NEM

(concealed mounting only)

To release manually, pull out the release button (1). The release button latches. In this position, the safety guard can be opened. To neutralise the blocked condition, push the release button once more (2). The release operation and cancelling the released condition may only be realised by an authorised person. The manual release must not be used when the machinery/plant is in operation.

TZF...NE

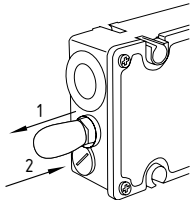

TZF...NEM

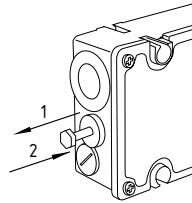

Emergency exit TZF...S.NF

(fitting and actuation only from within the hazardous area)

To release an emergency exit, the release button (1) must be pressed. In this position, the safety guard can be opened. The release button latches. To neutralise the release, the reset button (2) must be pressed. In the unlocked condition, the safety guard is protected against unintentional locking.

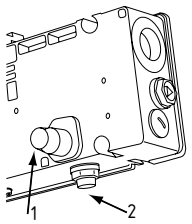

The user must evaluate and design the safety chain in accordance with the relevant standards and the required safety level.



The entire concept of the control system, in which the safety component is integrated, must be validated to the relevant standards.

2.4 Technical data

Standards:	EN IEC 60947-5-1, EN ISO 14119, BG-GS-ET-19
Enclosure:	glass-fibre reinforced thermoplastic, self-extinguishing
Actuator and locking bolt:	Galvanised steel / zinc die-cast
Contact material:	Silver
Coding level according to EN ISO 14119:	low
Degree of protection:	IP65, IP67
Contact type:	Change-over contact with double break type Zb or NC contact, with galvanically separated contact bridges
Switching system:	⊖ EN IEC 60947-5-1, slow action, NC contact with positive break
Connection:	screw terminals
Cable type:	solid wire (s) and stranded wire (f)
Cable section:	0.5 ... 2.5 mm ² , (with conductor ferrules max. 1.5 mm ²)
Cable entry:	M20 × 1.5
Rated impulse withstand voltage U _{imp} :	2.5 kV
Rated insulation voltage U _i :	250 V
Thermal test current I _{the} :	4 A
Utilisation category:	AC-15, DC-13
Rated operating current/voltage I _e /U _e :	4 A / 230 VAC 4 A / 24 VDC
Short-circuit protection (contacts):	4 A gG, D-fuse to EN 60269-1
Required rated short-circuit current:	1,000 A
Positive break travel (unlocked):	2 × 3.5 mm
Positive break force (unlocked):	20 N
Magnet switch-on time:	100 %
Rated control voltage U _c :	24 VDC
Power consumption:	max. 8.5 W
Ambient temperature:	0 °C ... +50 °C
Mechanical life:	> 1 million operations
Holding force F _{max} :	1,950 N
Holding force F _{zh} :	1,500 N
Latching force:	20 N
Actuating speed:	max. 20 m/min
Max. actuating frequency:	1,200 operations / h



Use copper wires only. Tightening torque: 0.8 Nm.
Use 60/75°C wire only. For use in NFPA 79 applications with listed or recognized cable glands only.
The power-source must be an isolated Limited voltage/ Limited Current protected by Maximum 4 A and maximum 24 Vdc.
The Information regarding Limited Voltage is only for LED-versions and must be marked in combination with the ordering code L.

2.5 Safety classification

Standards:	EN ISO 13849-1
Envisaged structure:	
- Basically:	applicable up to Cat. 1 / PL c
- With 2-channel usage and fault exclusion mechanism*:	applicable up to Cat. 3 / PL d with suitable logic unit
B _{10D} NC contact:	2,000,000
B _{10D} NO contact at 10% ohmic contact load:	1,000,000
Mission time:	20 years

* If a fault exclusion to the 1-channel mechanics is authorised.

$$MTTF_D = \frac{B_{10D}}{0,1 \times n_{op}} \quad n_{op} = \frac{d_{op} \times h_{op} \times 3600 \text{ s/h}}{t_{cycle}}$$

(Determined values can vary depending on the application-specific parameters h_{op} , d_{op} and t_{cycle} as well as the load.)

If multiple safety components are wired in series, the Performance Level to EN ISO 13849-1 will be reduced due to the restricted error detection under certain circumstances.

3. Mounting

3.1 General mounting instructions

i Please observe the relevant requirements of the standards EN ISO 12100, EN ISO 14119 and EN ISO 14120.

Three mounting holes are provided for fixing the enclosure. The solenoid interlock is double insulated. The use of an earth wire is not authorised. The solenoid interlock must not be used as an end stop. Any mounting position. The components however must be mounted so that the opening of the actuating head is protected against the penetration of dirt (e.g. sand, dust, chips). In case of painting activities, the components must be covered.

! If another actuating direction is desired, the four screws of the actuating head must be loosened. Turn the actuating head in the desired direction. Once the desired actuating direction is reached, two of the fixing screws on the actuating head must be replaced with the tamper-proof screws provided and tightened crosswise (tightening torque 0.5 Nm).

! In all ...CHI versions, the factory set actuating direction must not be changed. If the actuating direction of these versions is modified, the holding force F no longer is guaranteed.

! For power-to-unlock devices (TZF...), the actuator must be inserted when the actuating head is turned. Any non-observance of this prescription could result in the components being damaged.

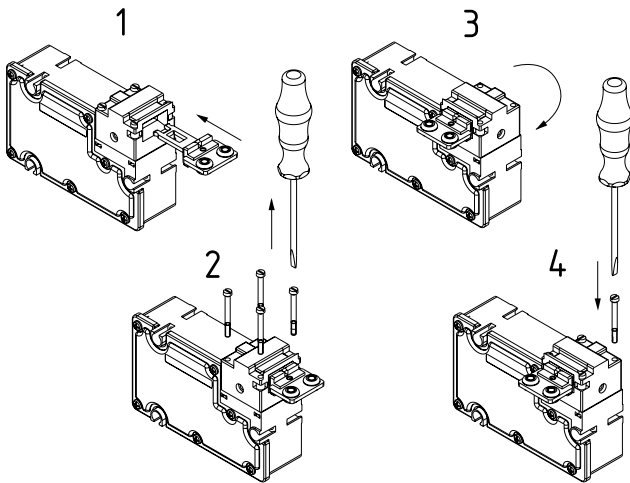

! When used in ambient temperatures > 40°C, the solenoid interlock must be protected against contact with inflammable materials or inadvertent personal contact.

! The safety component and the actuator must be permanently fitted to the safety guards and protected against displacement by suitable measures (tamperproof screws, gluing, drilling, pinning).

i The solenoid interlock and the actuator must be aligned with each other in such a way that the actuator can move into the solenoid interlock without stress throughout the safety guard's entire service life. A centring device can be used to prevent mechanical stress on the solenoid interlock and the actuator, e.g. caused by lowering the door.

3.3 Dimensions

All measurements in mm.

Solenoid interlock TZ...

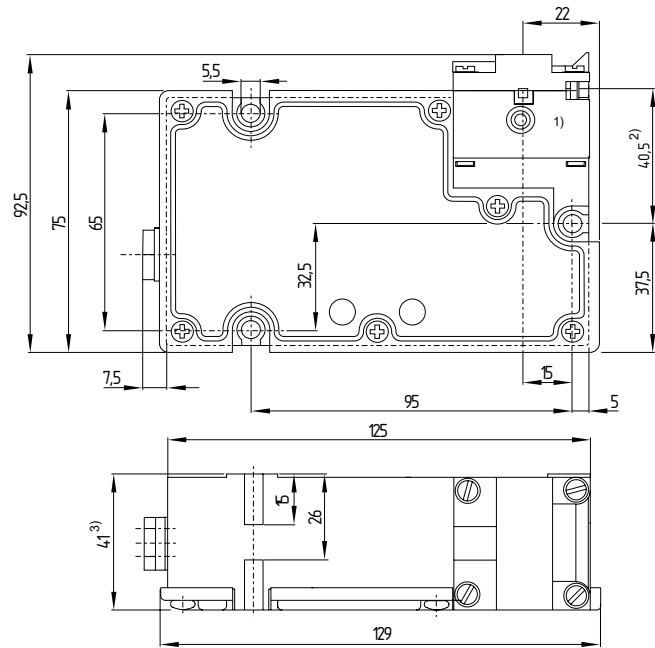

i **Device variant .CHI (no figure)**

- 1) The actuating head is rotated by 180°. A mounting angle is supplied to protect the actuating head.
- 2) The dimension 40.5 mm is increased to 50.5 mm.
- 3) The dimension 41 mm is increased to 44 mm.

4. Electrical connection

4.1 General information for electrical connection

! The electrical connection may only be carried out by authorised personnel in a de-energised condition.

! If the risk analysis indicates the use of a monitored interlock they are to be connected in the safety circuit with the contacts indicated with the symbol

For the cable entry, suitable cable glands with an appropriate degree of protection must be used.

After wiring, the wiring compartment must be cleaned (i.e. remove excess cables etc.). The fixing screws of the wiring compartment cover must be tightened with 0.8 Nm tightening torque.

i The monitoring contacts of the LED versions are not potential-free. In combination with these devices, only sequential circuits can be used, in which both channels are controlled with positive potential.

4.2 Cable

The cable entry is realised by a metric M20 gland. This gland must be measured by the user so that it is suitable for the cable used. A cable gland with suitable IP protection class must be used.

Settle length x of the cable at terminals of type s or f:

- Screw terminal standard (Cross slot): 8.0 mm
- Optional plastic screw terminal (Slot): 5.5 mm

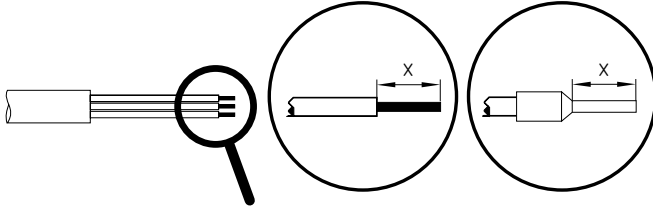

4.3 Contact variants

Contacts shown in de-energised condition and with the actuator inserted.

Power to unlock

TZF...

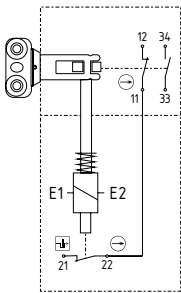

Power to lock

TZM...

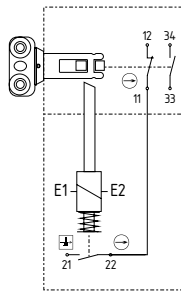

TZFW...

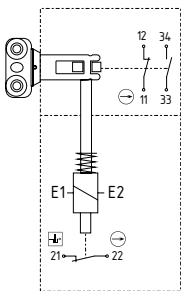

TZMW...

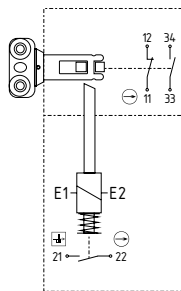

Power to unlock

TZFC...

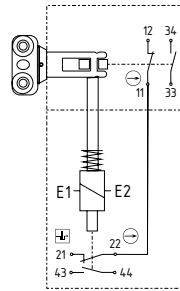

Power to lock

TZMC...

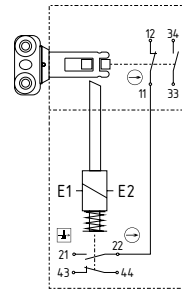

TZFCW...

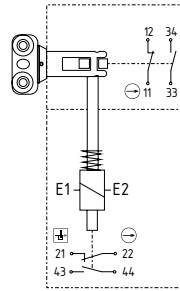

TZMCW...

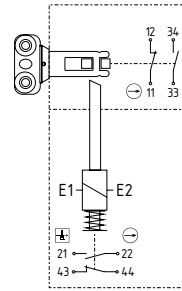

TZFL

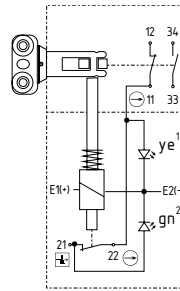

TZML

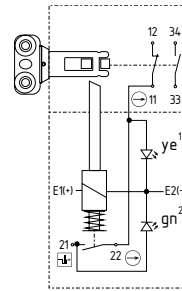

TZFWL

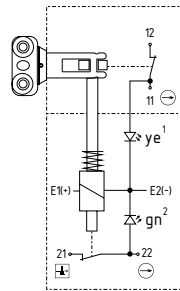

TZMWL

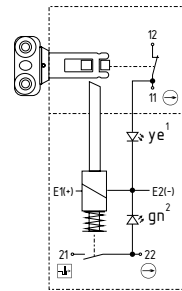

LED display

- 1) yellow = Safety guard closed
- 2) green = Safety guard closed and locked

Power to unlock

TZFW4OE

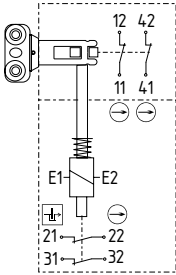

TZF3OE/1S

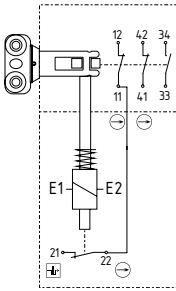

TZFW3OE

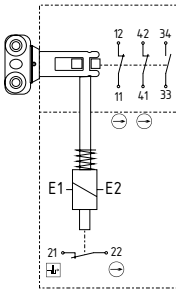

TZF3OE...-3053

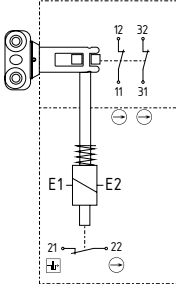

TZFW2MOE

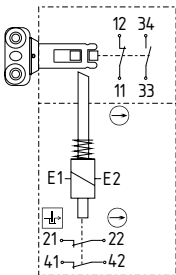

Key

- Positive break NC contact
- Monitoring the interlock according to ISO 14119

Power to lock

TZMW4OE

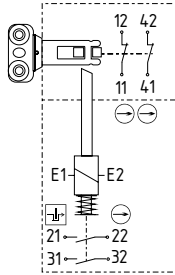

5. Set-up and maintenance

5.1 Functional testing

The safety function of the safety components must be tested. The following conditions must be previously checked and met:

1. Fitting of the solenoid interlock and the actuator.
2. Check the integrity of the cable entry and connections.
3. Check the switch enclosure for damage.

5.2 Maintenance

A regular visual inspection and functional test, including the following steps, is recommended:

1. Check for tight installation of the actuator and the switch.
2. Remove particles of dust and soiling.
3. Check cable entry and connections.



Adequate measures must be taken to ensure protection against tampering either to prevent tampering of the safety guard, for instance by means of replacement actuators.

Damaged or defective components must be replaced.

6. Disassembly and disposal

6.1 Disassembly

The safety switchgear must be disassembled in a de-energised condition only.

6.2 Disposal



The safety switchgear must be disposed of in an appropriate manner in accordance with the national prescriptions and legislations.

7. Declaration of conformity

We hereby certify that the hereafter described components both in their basic design and construction conform to the applicable European Directives.

Relevant Directives:



2006/42/EC
2011/65/EU

Applied standards:

EN IEC 60947-5-1:2025
EN ISO 14119:2025



The currently valid declaration of conformity can be downloaded from the internet at products.schmersal.com.

K.A. Schmersal GmbH & Co. KG

Mödinghofe 30, 42279 Wuppertal
Germany

Phone: +49 202 6474-0

Telefax: +49 202 6474-100

E-Mail: info@schmersal.com

Internet: www.schmersal.com

Production site:

Schmersal India Private Limited

G-7/1, MIDC, Ranjangaon

Tal. Shirur, Dist. Pune – 412 220

Maharashtra

India

Phone: +91 21 38 61 47 00

E-Mail: info-in@schmersal.com

Internet: www.schmersal.in