



EN Operating instructions.pages 1 to 24
Original

Content

1 About this document

1.1 Function 1

1.2 Target group: authorised qualified personnel. 1

1.3 Explanation of the symbols used 1

1.4 Appropriate use 1

1.5 General safety instructions 1

1.6 Warning about misuse 1

1.7 Exclusion of liability 2

2 Product description

2.1 Ordering code 2

2.2 Special versions. 2

2.3 Purpose 2

2.4 Technical data 2

2.5 Safety classification 3

3 Mounting

3.1 General mounting instructions 3

3.2 Disassembly. 3

3.3 Disposal 3

4 Electrical connection

4.1 General information for electrical connection. 4

4.2 Terminal coding 4

4.3 Power supply 4

4.4 Start level. 4

4.5 Sensor level. 4

4.6 Actuator level. 5

5 Operating principle and settings

5.1 Connection / operating elements 5

5.2 Description of the terminals 5

5.3 Start level. 6

5.4 Sensor level. 6

5.5 Actuator level. 6

5.6 Project planning 6

5.7 Configuration 6

6 Set-up and maintenance

6.1 Operating the safety module 8

6.2 Putting into operation for the first time 8

6.3 Configuration 9

6.4 Behaviour in the case of faults. 9

6.5 Maintenance 9

7 Menu structure

7.1 Menu structure - Safety module. 9

8 Appendix

8.1 Application programs 10

8.2 Error message, warning and status indication. 21

9 EU Declaration of conformity

1. About this document

1.1 Function

This operating instructions manual provides all the information you need for the mounting, set-up and commissioning to ensure the safe operation and disassembly of the safety-monitoring module. The operating instructions must be available in a legible condition and a complete version in the vicinity of the device.
This document constitutes operating instructions within the meaning of the Machine Directive 2006/42/EC Annex I, Article 1.7.4.

1.2 Target group: authorised qualified personnel

All operations described in this operating instructions manual must be carried out by trained specialist personnel, authorised by the plant operator only.
Only install and commission the device once you have read and understood these instructions and are acquainted with the applicable regulations on machine safety and accident prevention. The selection and installation of the devices and the technical incorporation into the control system require qualified knowledge of the pertinent laws and requirements set out in standards.

1.3 Explanation of the symbols used



Information, hint, note:
This symbol indicates useful additional information.



Caution: Failure to comply with this warning notice could lead to failures or malfunctions.
Warning: Failure to comply with this warning notice could lead to physical injury and/or damage to the machine.

1.4 Appropriate use

The Schmersal range of products is not intended for private consumers.

The product described here has been developed to assume safety-oriented functions as part of an overall system or machine. The safe state corresponds to the de-energised state.
It is the responsibility of the manufacturer of a machine or plant to ensure the correct functionality of the entire machine or plant. The safety-monitoring module must be exclusively used in accordance with the versions listed below or for the applications authorised by the manufacturer. Detailed information regarding the range of applications can be found in the chapter 2.

1.5 General safety instructions

The user must observe the safety instructions in this operating instructions manual, the country specific installation standards as well as all prevailing safety regulations and accident prevention rules.



Further technical information can be found in the Schmersal catalogues or in the online catalogue on the Internet: products.schmersal.com.

There are no residual risks, provided that the safety instructions as well as the instructions regarding mounting, commissioning, operation and maintenance are observed.
All information without guarantee. Subject to change.

1.6 Warning about misuse



If used incorrectly or not for the intended purpose or in the case of tampering, danger to persons or damage to machine and system parts from using the safety module cannot be ruled out.



1. Range of application (compendium)
This part of EN ISO 13856-1 is applicable to pressure-sensitive mats and pressure-sensitive floors, regardless of the type of energy used (e.g. electrical, hydraulic, pneumatic or mechanical), designed to detect

- persons weighing more than 35 kg, and
- persons (e.g. children) weighing more than 20 kg.

It is not applicable to detect persons weighing less than 20 kg.

1.7 Exclusion of liability

We shall accept no liability for damages and malfunctions resulting from defective mounting or failure to comply with the operating instructions manual. The manufacturer shall accept no liability for damages resulting from the use of unauthorised spare parts or accessories.

For safety reasons, invasive work on the device as well as arbitrary repairs, conversions and modifications to the device are strictly forbidden, the manufacturer shall accept no liability for damages resulting from such invasive work, arbitrary repairs, conversions and/or modifications to the device.

2. Product description

2.1 Ordering code

This operating instructions manual applies to the following types:

PROTECT-SELECT-CC | Standard version
PROTECT-SELECT-OEM-①-② | OEM version

No.	Option	Description
①		9-position customer number
②		6-position project number

2.2 Special versions

For special versions, which are not listed in the ordering code below 2.1, these specifications apply accordingly, provided that they correspond to the standard version.

For special versions, the supplementary operating instructions are to be observed.

2.3 Purpose

The safety module for integration in safety circuits is designed to fit in control cabinets.

The safety module is for the safe evaluation of floating and OSSD-type safety switchgear and secure analogue signals as well as switch mats in accordance with EN ISO 13856-1.

The logical switching of the inputs to the outputs is determined by a pre-programmed application program. To be able to adapt to each of the application uses the application program has adjustable parameters. Setting the parameters is done using the safety module with a rocker switch in conjunction with a colour display.

The safety function is the safe shutdown of the safety outputs (Q0 to Q3 and QR1 to QR2) upon request via the safety inputs (I0 to I17 and AI0 to AI1) and in the event of a fault. In the switched off state the outputs have no power this means that relay output contacts are open and semiconductor outputs are non-conducting.

To determine the Performance Level (PL) of the entire safety function (e.g. sensor, logic, actuator) to EN ISO 13849-1, an analysis of all relevant components is required.

The safety-related current paths with the outputs Q0 to Q3 and (taking into account a B10₀ value consideration) QR1 and QR2 meet the following requirements:

- Category 4 – PL e to EN ISO 13849-1
- corresponds to SIL 3 to EN IEC 62061



The entire concept of the control system, in which the safety component is integrated, must be validated to the relevant standards.



If the monitoring of an Emergency-Stop command device is not implemented using the safety module PROTECT SELECT the monitoring must take place using another suitable manner.

2.4 Technical data

General data

Standards:	EN 60204-1, EN 60947-5-1, EN IEC 62061, EN ISO 13849-1, IEC 61508
Mounting:	snaps onto standard rail to EN 60715
Dimensions (W/H/D):	52.5 x 100 x 118 mm
Weight:	300 g
Readiness after switching on:	approx. 6 s

Mechanical data

Connection type:	cage clamps
Cable type:	rigid single-wire, rigid multi-wire or flexible
Cable section:	0.25 ... 2.5 mm ² (incl. conductor ferrules)

Mechanical life:	10 ⁷ operations
Electrical life:	Derating curve available on request
Resistance to shock:	to EN 60068-2-27
Resistance to vibrations:	to EN 60068-2-6

Ambient conditions

Ambient temperature:	-25 °C ... +55 °C, no condensation, with vertical installed position
Storage and transport temperature:	-25 °C ... +75 °C, no condensation
Climatic conditions:	Humidity 15 % ... 90 %, no condensation

Degree of protection:	IP20
Installation compartment:	earthed, lockable switch cabinet with degree of protection IP54
Air clearances and creepage distances:	EN 50178 (double insulation)
EMC rating:	EN 61000-6-2, EN 61496-1, IEC 61326-3-1
EMC interference radiation:	EN 61000-6-4
Overvoltage category:	III
Degree of pollution:	2

Electrical Data

Rated operating voltage:	24 VDC +/- 10%
Fuse rating:	3 A slow blow external
Power consumption at 24 VDC:	max. 500 mA, internally fused plus load current

Safety digital inputs

Number:	18 single channel / up to 9 dual channel inputs
Voltage / current:	24 V; 6 mA
Level (nominal):	
- Low:	-3 V ... 2.0 V
- High:	18 V ... 28.8 V
Category / PL / SIL CL	:
- Single channel, with minimum Request interval = 30 h:	Cat. 2 / PL d / SIL CL 2
- Dual channel:	Cat. 4 / PL e / SIL CL 3

Safe analogue inputs

Number:	2
Measuring range voltage:	0 ... 10 V
Voltage change:	Sinusoidal: max. 2.8 Hz, max. 25 V/s
Measuring range current:	
- with external shunt resistor:	0 ... 20 mA
- 500 Ω / 0.5W / < 1%:	4 ... 20 mA
Current change:	Sinusoidal: max. 2.8 Hz; max. 50 mA/s
Input resistance:	10 kΩ
Category / PL / SIL CL:	
- Single channel (If a cable break dominates):	Cat. 3 / PL d / SIL CL 2
- Dual channel:	Cat. 4 / PL e / SIL CL 3
Accuracy:	3%
Resolution:	12 Bit

Safe semi-conductor outputs

Number (p-/n-switching):	2
- Note:	with OEM -version an activation of the second p+n-switching output Q1/Q1N is possible. In this case a derating must be observed.
Number (p switching):	2
Max. current at 24V:	0.7 A / output, resistive load, short-circuit proof
Output test pulse:	type 0.5 ms; max. 2 ms, with a capacitive load
Category / PL / SIL CL:	
- Single channel, with minimum Request interval = 47min:	Cat. 2 / PL d / SIL CL 2
- Dual channel:	Cat. 4 / PL e / SIL CL 3
Reaction times:	
- Digital inputs:	Switching off: < 30 ms Switching on: < 45 ms
- Analogue inputs:	Switching off: < 100 ms Switching on: < 120 ms
- Note:	The stable time must be added to the specified ON times.
Voltage drop:	
- Residual current:	< 1 V, < 2 mA
- Leakage current in the case of error:	< 1 mA
Minimum operating current:	> 5 mA
Required short-circuit current:	9 A

Safe relay outputs

Number:	2 (common access)
Contact load capacity (B _{10D} values see below):	
- AC-1:	240 V / 4 A
- AC-15:	240 V / 3 A
- DC-1:	24 V / 4 A
- DC-13:	24 V / 4 A / 0.1 Hz
Category / PL / SIL CL:	
- Single channel:	Cat. 1 / PL c / SIL CL 1
- Dual channel:	Cat. 4 / PL e / SIL CL 3
Residual current at 24V:	4 A
Fuse rating:	4A gL/gG (for residual current)
Reaction times:	
- Digital inputs:	Switching off: < 50 ms Switching on: < 65 ms
- Analogue inputs:	Switching off: < 120 ms Switching on: < 140 ms
- Note:	The stable time must be added to the specified ON times.
Required short-circuit current:	1000 A to EN 60947-5-1
Rated isolated voltage:	to EN 50178, double insulation

Signalling outputs

Number, optional:	4
Max. current at 24V:	0.1 A, resistive load, conditionally short-circuit proof

Test pulse outputs

Number:	3
Max. current at 24V:	0.1 A, resistive load, conditionally short-circuit proof
Switch-off test pulse:	<1.5 ms

cULus LISTED 382E

Main supply:	24 V, Class 2
Consumption:	2.6 A
Ambient temperature:	+ 55°C
Semiconductor output current:	sum 2.1 A
Relay output:	C300, R300

2.5 Safety classification

Standards:	EN ISO 13849-1, EN IEC 62061, IEC 61508
PL:	up to e
Category:	up to 4
DC:	high
CCF:	> 65 points
SIL CL:	up to 3
SFF:	> 90 %
PFH _d to IEC 61508 Parts 1-7:	1.78 x 10 ⁻⁸ 1/h
- Note:	Valid for dual channel and 60% relay load.
Mission time:	20 years
Hardware fault tolerance:	1
Mode of operation:	High demand / continuous
MTTF _D (inputs+logic):	>100 years
MTTF _D (semi-conductor outputs):	>100 years
B _{10D} value (for one channel of the relay output):	Low load range 20%: 10,000,000 40%: 7,500,000 60%: 2,500,000 80%: 1,000,000 Maximum load 100%: 400,000

$$MTTF_D = \frac{B_{10D}}{0,1 \times n_{op}} \quad n_{op} = \frac{d_{op} \times h_{op} \times 3600 \text{ s/h}}{t_{cycle}}$$

For an average annual demand rate of n_{op} = 126,720 cycles per year, Performance Level PL e can be obtained at maximum load.

n_{op} = average number of activations per year
d_{op} = average number of operating days per year
h_{op} = average number of operating hours per day
t_{cycle} = typical demand of the safety function in s
(e.g. 4 × per hour = 1 × per 15 min. = 900 s)

(Determined values can vary depending on the application-specific parameters h_{op}, d_{op} and t_{cycle} as well as the load.)

The MTTF_D value results as follows

Semi-conductor output: 1/MTTF_D (inputs+logic) + 1/MTTF_D (semi-conductor outputs)
Relay output: 1/MTTF_D (inputs+logic) + 1/MTTF_D (relay)

3. Mounting



The safety module should only be installed and removed when without power.

3.1 General mounting instructions

Snap the bottom of the enclosure slightly tilted backwards in the standard rail and push down until it latches in position.



Depending on requirements, the connector plugs can be coded individually using the supplied coded pins. Electrical power cables must be routed separately from communication lines.

3.2 Disassembly

Unlock the bottom of the enclosure by means of a slotted screwdriver, push up and hang out slightly tilted forwards.

3.3 Disposal

After the maximum service life of 20 years, the security module should be disposed of properly in accordance with national laws and regulations.

4. Electrical connection

4.1 General information for electrical connection



The electrical connection may only be carried out by authorised personnel in a de-energised condition!

Settle length x of the cable at terminals of type s, f or r:

10 mm



4.2 Terminal coding

The connector parts can be coded by inserting coding profiles into the grooves provided. The coding tabs are inserted into the corresponding recesses on the basic enclosure.

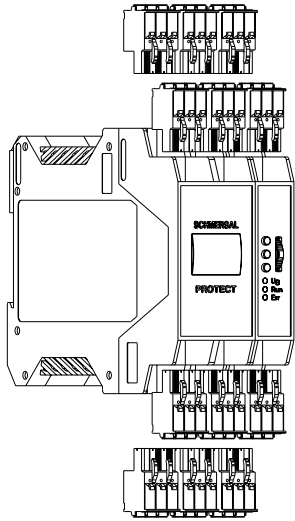

4.3 Power supply

A1: 24 VDC \pm 10% (via external safety fuse 3 A slow blow)
A2: GND, this must be connected to the protective earth (PE).
FE: Functional earth (short line where possible min. 1.5 mm²)



Requirements placed on the power supply unit
- Safety mains transformer in accordance with EN 61558 / VDE 0570 Part 2-6
- Switching power supply unit in accordance with EN 60950-1 and EN 50178. The power supply unit must be suitable to supply SELV current circuits in accordance with EN 60950-1.



The FE connection (functional ground) must be connected to PE.



If A2 and PE do not have a connection, FE must be connected to A2.

4.4 Start level

Number and terminal will depend on the application program (see chapter 8.1).

4.5 Sensor level

Number and terminal will depend on the application program (see chapter 8.1). All inputs are plus-switching.



Input circuits which have been deactivated via the parameter assignment may not be connected.

Wiring examples Sensors



The actual pin assignment can be found in the description of the respective application program (see section 8.1).

2-channel potential-free with cross-wire monitoring

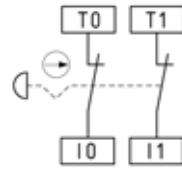

2-channel potential-free without cross-wire monitoring

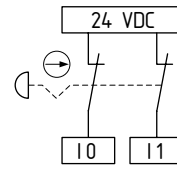

2-channel electronic output (cross-wire monitoring via sensor)

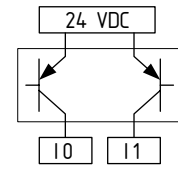

2-channel potential-free with NO and NC contacts

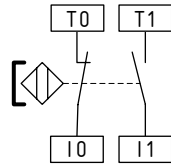

Switch mat (Schmersal type SMS 4)

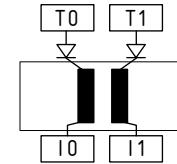

1-channel potential-free connection first contact

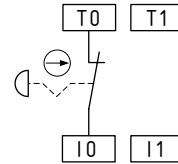

Safety mat to EN ISO 13856-1

- In combination with SMS safety mat (from Schmersal)
- With reset function
- The connection of the inputs is realised through the safety mat here.
- When the safety mat is actuated, the potentials of both inputs are connected, so that a cross-wire short is created and the device is safely shut down.
- Category 3 – PL d to EN ISO 13849-1 possible



Proximity switches with Reed contacts (e.g. safety switches such as the Schmersal BNS type series) may not be connected to inputs (I0, I4, I12, I14) due to the alternative function as signalling output. They must satisfy the following technical requirements

- switching capacity: min. 240 mW
- switching voltage: min. 24 VDC
- switching current: min. 10 mA



When a safety mat is connected make sure that the clock outputs are decoupled, for example via diodes.



When installing the cables the safe analogue inputs AI0 / AI1 high frequency signal decoupling must be avoided.



Recommended cable type for the safe analogue inputs AI0 / AI1: LAPP KABEL unitronic® FD CP (TP) plus 1 x 2 x 0.75



For further information regarding possible applications using the analogue inputs, please contact our technical sales department.



For inputs that are configured for antivalent (1NO/1NC) evaluation, the NO contact must always be connected to the input with the odd number.



With single-channel use the input with the even number is not used.



When connecting safety door interlocks the door position should be connected to the even input and magnet position connected to the odd input.

4.6 Actuator level

- 2 x safe p-/n-switching semiconductor outputs (Q0/Q0N, Q1/Q1N) with 24 VDC
- 2 x safe p-switching semiconductor outputs (Q2, Q3) with 24 VDC
- 2 x safe relay outputs (QR1, QR2) with common supply (QR0) up to 250 VAC or 24 VDC
- 4 x operational optional message outputs (Y0 ... Y3) with 24 VDC

Relay outputs

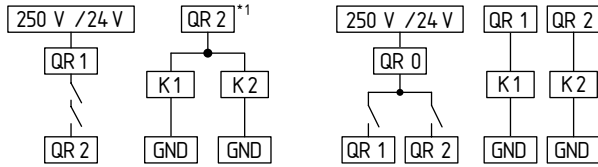

Semi-conductor outputs

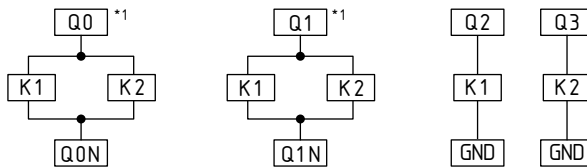

*1 Measures for short circuit shutout against the supply are necessary

Test pulses

The correct function of the semi-conductor outputs is secured by a cyclical test, i.e. all switched outputs are deactivated for approx. 0.5 ms (in the event of capacitive loads the deactivation is for a maximum of 2 ms).



If contactors and coils are connected suitable protective measures (free-wheeling diode, varistor or similar) must be taken to protect the internal output switching.



If after a shutdown of max. 2 ms no HIGH signal is detected on the semiconductor output (e.g. due to a capacitive load), a system failure is the result.



If a subsequent assembly is disturbed by the test pulse it can be eliminated by including a D/C filter in the circuit:
 Typical values: 3...10 kΩ, 1000 nF
 10...30 kΩ, 330 nF
 The resulting signal delay is to be considered.

Signalling outputs

The terminals I0/Y0, I4/Y1, I12/Y2 and I14/Y3 may be used both as safe input and as signalling output. Which function is used will depend on the application program (see chapter 8.1).



The signalling outputs Y0...Y3 are not safety-related.

5. Operating principle and settings

5.1 Connection / operating elements

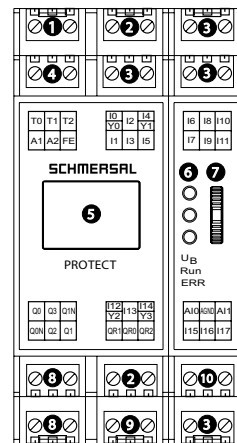

- 1 Cycle outputs T0...T2
- 2 Safe inputs / optional signalling outputs
- 3 Safe inputs
- 4 Supply voltage
- 5 Graphic colour display
- 6 Status LEDs
- 7 Rocker switch
- 8 Safe semi-conductor outputs
- 9 Safe relay outputs
- 10 Safe analog inputs

Operating the rocker switch

Up/down: Navigation through the menu and the input masks.
Press: Acceptance of the entry or confirmation of an action.

LED indications

U _B lights up	Operating voltage applied
Run lights up	Operating mode
blinking	Configuration mode or module has the factory defaults (see initial parameterization)
ERR illuminates	A fault is present (safe condition)
blinking	There is a caution or warning (Operation with possible limitations)

Fault / Warnings / Messages appear on the display in plain text.

Menu structure

The complete structure may be derived from Chapter 7.

5.2 Description of the terminals

Voltage	A1	+24 VDC
	A2	0 VDC
	FE	Functional earth connection
Inputs	I0...I17	Safety digital inputs
	AI0	Safe analogue input
	AI1	Safe analogue input
	AGND	Analogue ground
Outputs	Q0, Q0N	Safe semi-conductor output p-/n-switching
	Q1, Q1N	Safe semiconductor output p-/n-switching (only available OEM-products)
	Q2	Safe semi-conductor output p-switching
	Q3	Safe semi-conductor output p-switching
	QR0	Supply of safe relay output
	QR1	Safe relay outputs
	QR2	Safe relay outputs
	Y0...Y3	Operational outputs (signalling output)
	T0...T2	Clock outputs for the supply of safe digital inputs for short-circuit recognition

5.3 Start level

Alternatively: Auto-start or manual start (falling edge)
Optional: Feedback circuit (EDM), start-up testing

Start-up test

After switching on the supply voltage again the protective device must first be opened and closed again before the enable can be activated with the start/RESET button.

5.4 Sensor level

18 safety digital inputs

Selectable: 1-channel of 2-channel, equivalent, antivalent or deactivated.
Optional condition: Short circuit recognition, discrepancy monitoring

2 safe analogue inputs

2 analogue safe 1-channel inputs each with 4 adjustable limit values or 1 analogue safe 2-channel input with 4 adjustable limit values and adjustable monitoring of the percentage (of maximum value = 4095) channel deviation.

Discrepancy monitoring

After a request for a 2-channel protection device that is carried out by only one of the input channels, both input channels must be opened and closed again before the release with the START / RESET button can be activated.

Short-circuit recognition

Measure for detecting short circuits between the input channels for 2-channel operation. The cross-circuit detection is achieved here by the use of clock outputs T0 ... T2 using floating safety sensors. The assignment of the clock outputs to the inputs is fixed. The setting takes place in the inputs menu.



To reach cat. 4 / PL e / SIL CL 3, cross-circuit detection must be enabled in floating safety sensors.

Test pulse outputs	Digital inputs I0 ... I17 (optional signalling outputs Y0 ... Y3)					
T0 closed	I0 (Y0)	I3	I6	I9	I12 (Y2)	I15
T1 closed	I1	I4 (Y1)	I7	I10	I13	I16
T2 closed	I2	I5	I8	I11	I14 (Y3)	I17

Analogue limit values

The limit values are set with a number of between 0 to 4095. The following conversion applies:

Limit value = Voltage [V] x 337

5.5 Actuator level

The actuator level consists of:
2x p-/n-switching safe outputs
2x p-switching safe outputs
2x safe relay outputs
4x optional signalling outputs
Each safe output can be switched off either without delay (Stop 0) or delayed (Stop 1) via safe timer.

5.6 Project planning

The planner selects the suitable application program and stipulates the necessary parameter assignment data. All information must be entered by setting instructions for the person charged with commissioning. The person charged with commissioning transfers this data to the safety module and verifies the correct parameter assignment and wiring. The following sequence must be observed for planning:

1. Definition of the safety function and determination of the requisite PL / Cat. / SIL.
2. Selection of the suitable application program.
3. Assignment of the periphery to the terminals.
4. Stipulation of the necessary additional functions.
5. Stipulation of which inputs require cross-wire detection.
6. Analogue inputs: stipulation of the type and limit values.
If not used, lay AI0+AI1 to AGND and values to 4095.
7. Setting wiring plan.
8. Determination of the MSP code (see chapter 5.7).
9. Entry of the MSP code and additional functions in the setting instructions.
10. Entry of the cross short settings in the setting instructions.
11. Entry of the requisite timer values.
12. Entry of the analogue settings.
13. Enter the desired PIN.
The following PINs are not allowed:
- 0000, 0001, 0815, 4711
- 1111, 2222, 3333, 4444, 5555, 6666, 7777, 8888, 9999
- 0123, 1234, 2345, 3456, 4567, 5678, 6789
- 9876, 8765, 7654, 6543, 5432, 4321, 3210
14. Sign setting instructions.

5.7 Configuration

Multifunctional sensor processor (MSP)

An input circle is analysed using a multifunctional sensor processor (MSP) which is parameter-assigned by a three-digit hexadecimal number. The 1st position describes the sensor, the 2nd position describes the additional function and the 3rd position describes the contact properties.

The entry of the MSP code is from right to left.

MSP code	Sensor type (Position 1)	Feature
0	Sensor evaluation deactivated	<ul style="list-style-type: none"> - There is no evaluation of a connected sensor! - Upon detection of a signal, an error message is generated on the screen! - Upon detection of a signal, all safety outputs are disabled!
1	Emergency stop control unit	Evaluation of the internal clock signals of the clock outputs T0 to T2 Setting = Cross-wire short
2	Safety switch (contact) e.g. AZ16	Evaluation of the internal clock signals of the clock outputs T0 to T2 Setting = Cross-wire short
3	Interlock (electro-mechanical, magnetic and actuator switch) e.g. AZM150, AZM161, AZM170	<ul style="list-style-type: none"> - Direct activation of the interlock (power supply for the magnet) over the semiconductor outputs Q0 / Q0N - Evaluation of the internal clock signals of the clock outputs T0 to T2 - Setting = Cross-wire short - No simultaneous evaluation of the solenoid and actuator contacts - The monitoring time is automatically set to infinity
4	Electronic solenoid interlock e.g. AZM40, AZM201, AZM300, AZM400, MZM100	<ul style="list-style-type: none"> - Direct activation of the interlock (power supply for the magnet) over the semiconductor outputs Q0 / Q0N - Evaluating signals of the safety sensors - No evaluation of the internal clock signals of the clock outputs T0 to T2 - Setting = Standard - Simultaneous evaluation of the solenoid and actuator contacts
5	Non contact safety switch e.g. BNS 260	<ul style="list-style-type: none"> - Evaluation of the internal clock signals of the clock outputs T0 to T2 - Setting = Cross-wire short
6	Safety mat SMS4 / SMS5 to EN ISO 13856-1 (4-wire)	<ul style="list-style-type: none"> - Evaluation of the internal clock signals of the clock outputs T0 to T2 - Setting = Safety mat
7	AOPD e.g. SLC/SLG440 Electronic safety sensors e.g. RSS36/CSS sensors	<ul style="list-style-type: none"> - Evaluating signals of the safety sensors - No evaluation of the internal clock signals of the clock outputs T0 to T2 - Setting = Standard - Test pulses by the sensor can be tolerated

Additional functions (Position 2)				
MSP code	Discrepancy error monitoring	Start-up test	Feedback circuit	Autostart
0				
1				•
2			•	
3			•	•
4		•		
5		•		•
6		•	•	
7		•	•	•
8	•			
9	•			•
A	•		•	
B	•		•	•
C	•	•		
D	•	•		•
E	•	•	•	
F	•	•	•	•

Contact properties (Position 3)			
0	Equivalent	(e.g. 2 NC contacts)	Standard setting
1	Antivalent	(e.g. 1 NC contact, 1 NO contact)	
2	Single channel	(e.g. 1 NC contact)	

Example, MSP code:

Emergency stop command device with active discrepancy monitoring, feedback loop and 2 NC contacts.

MSP	0	A	1	= E-stop command device
	Position 3	Position 2	Position 1	

Input sequence from right to left ←



If the additional function "Discrepancy monitoring" is not used in a two-channel sensor, this should be especially justified in the risk analysis.



Door interlocking mechanisms have an infinite discrepancy, this allows the additional function to be used for error detection. With an activated discrepancy monitoring the interlock has to be opened after an unlocking request.



Contact property (3rd position) = single-channel: The input with the even number is always evaluated (e.g. sensor on I2 and I3 the input I2 single-channel is evaluated). The odd input must remain open.



Sensor type 0 (deactivate): With a HIGH signal to the sensor inputs of a disabled sensor all safety clearances are deactivated.



On deactivation of auto-start the function of monitored start is selected.

Further Parameter

Interlock type	
Power to unlock	For spring-locked guard interlocks.
Power to lock	For solenoid-locked guard interlocks.



The interlock type always applies to all connected guard interlocks.

Analog inputs

Dual Sensor	2-channel analysis of AI0 and AI1 with percentage tolerance between the two channels.
Single sensor	Single channel analysis of AI0 and AI1.

In addition to the input type, 4 limit values can be set for every input (if "Dual Sensor" is selected for both).

Inputs

Standard	(S)	No cross-wire detection for input active.
Cross-wire short	(C)	Cross-circuit detection for this input is active.
Safety mat	(M)	Connecting a 4-wire safety mat. Cross-circuit detection for this input is active.

Times

Each MSP has a safety switch device input filter for bounce on protective equipment, or detection of failures.

Monitoring time / discrepancy time

Maximum tolerated delay between the channels of a 2-channel input. If exceeded a warning on the screen is displayed and the indicator light ERR flashes. Both channels must be opened to clear before the input can be activated again. Unless otherwise specified, this time is set to 10s (guard interlocks set to infinity).

Stable time

During the stable time (default value = 0.1 s) there is a debounce time, which causes a turn-on delay. The release of the safety function only takes place when both input contacts are switched stable for the duration of the stabilizing time.

Operating situation

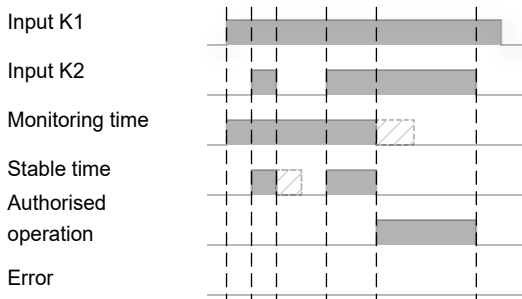

Fault situation

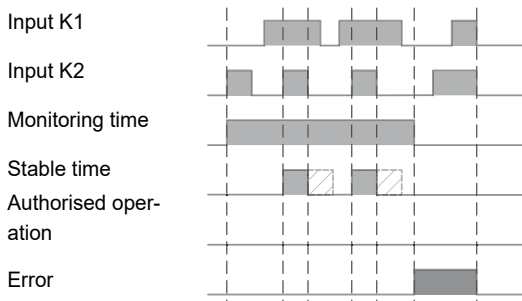

The setting for the monitoring time / discrepancy time and stable time must be greater than zero.

6. Set-up and maintenance

The person putting into operation for the first time makes the necessary settings on the safety module using the setting instructions and then verifies these. The following sequence is to be observed.

1. Make settings in accordance with the setting instructions.
2. Compare the read-back displays with the setting instructions.
3. Enter the parameter program CRC in the setting instructions.
4. Perform acceptance check (checking of function, correct wiring, polarity of the actors,).
5. Sign setting instructions and minutes of the acceptance check.
6. Add setting instructions and minutes of the acceptance check to the machine documentation.

6.1 Operating the safety module

The safety module is operated using the rocker switch. If an entry is emphasised by a coloured bar (cursor), the menu can be navigated by moving the switch up and down. The current entry is selected by pressing on it. If this is a parameter, the value can now be set ("up/down"). The value is similarly accepted by pressing the rocker switch. If you actuate "up" the first time you enter a menu, you will reach the higher ranking menu. If the screen saver appears (a moving circle), this is similarly left by pressing the rocker switch. The term ENTER used in the further description for pressing the rocker switch.

6.2 Putting into operation for the first time

1. After switching on the start screen appears.
2. The request is then made to select the menu language (default: English).
3. The necessity for a configuration / parameter setting is displayed after ENTER.
4. Confirm by ENTER.
5. To conduct the configuration a PIN must be entered (factory default: 0000). The entry is made number by number using the rocker switch (up/down). The next number is reached by ENTER.
6. After correct entry the "Safety module configuration" screen appears.
7. Enter the menu by ENTER. Now select the desired program and confirm with ENTER.
8. The list of the MSP codes now appears for the input circuits. Set the corresponding code for every MSP in accordance with the list. After entry a plain text display of the selected settings appears. ENTER moves back to the code list display. If you navigate "up" with the last MSP code, the next menu appears.
9. If a guard lock is used the selection of the type will appear (Power to unlock: Yes/no).
10. Now set the requisite values for the analogue inputs and times.

SCHMERSAL

PROTECT
SELECT

Language

English

CAUTION!

Module needs to be
configured first!

Enter PIN

0000

Configuration
Safety module

Program select

Prog 01
Prog 02
Prog 03
Prog 04

Input circuit code

MSP 01: 1 A 5
MSP 02: 3 6 8
MSP 03: 1 E 7

MSP 03: (1 E 7)

E-Stop 2K
NC/NG start
Feedback circuit
Start-up + Cycl. Test

Solenoid interlock

Power to unlock

Parameter

Analog inputs
Inputs
Times

- Once all settings have been made, leave the menu by moving "Up" until the query "Save Yes/No" appears. Confirm with "Yes". All parameters are then shown on several screen pages (red background). All parameters are marked with "M" (modified). Check all values once more and scroll further with "ENTER".
- After display of "Readback completed" you will reach the PIN entry.
- First enter the factory set PIN 0000.

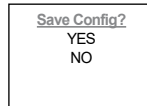

- Then you must enter and repeat the new PIN from the settings instructions.

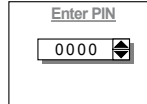

- The CRC which is now shown must be entered in the settings instructions.

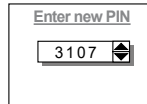

6.3 Configuration

The setting is made essentially as described in chapter 5.7.

Alternatively:

If the logo appears after switching on, the display of the set program is first reached by pressing the rocker switch and then the main menu. If no logo appears, but an SPS message, move "Up" until you reach the main menu. Select "Configuration" here. The PIN to be entered is now the one on the settings instructions. The sequence corresponds to "Putting into operation for the first time". For the final parameter display with red background only altered values marked with a blue "M" are shown and must be checked specially.



LED RUN

lights up: operating mode
blinking: Configuration mode or module has the factory defaults (see initial parameterization)

6.4 Behaviour in the case of faults

In the event of a fault the following procedure is recommended

- UB LED dark: Check voltage supply
- ERR LED lights up/flashes: Analyse error message on the display and arrange for appropriate actions.
- ERR LED dark: Fault cannot be diagnosed by PROTECT SELECT.
Action: Check the external cabling



LED ERR

illuminated: There is a fault (safe condition)
blinking: There is a caution or warning (Operation with possible limitations)
Fault / Warnings / Messages appear on the display in plain text.

6.5 Maintenance

A regular visual inspection and functional test, including the following steps, is recommended:

- Check the correct fixing of the safety module
- Check the cable and device for damage/manipulation indications
- Check electrical function
If relay outputs are used:
 - For PLd (Cat. 3) / SIL 2 (with HFT 1) at least every 12 months or
 - for PLe (Cat. 3 or 4) / SIL 3 (with HFT 1) at least once a month.
 Otherwise: at least once every 12 months.



Damaged or defective components must be replaced.

7. Menu structure

7.1 Menu structure - Safety module

Status

↳ Safety module

↳↳ Inputs

Display of status of the inputs.

↳↳ Outputs

Display of status of the outputs.

↳↳ Analogue AI0

Display of the current analogue values and status of the set limit values.

↳↳ Analogue AI1

Display of the current analogue values and status of the set limit values.

↳ System

↳↳ Operating duration

Display of the time at which the system was activated.

Warnings



If the ERR display flashes the warnings can be shown here.

↳↳ History

Display of the last changes of the inputs/outputs.

Error message



If the rocker switch is pressed in this menu, a new start is possible.

↳ Error code

Internal error code

↳ Error message

Plain text message of the error code

↳ Troubleshooting

Description of possible error cause and rectification measures

↳ Restart

Trigger of a new start once the error has been eliminated.

Configuration



Enter PIN

Entry of the PIN codes so as be able to perform the configuration.

Safety module

Program select

Selection of one of the application programs. With the SELECT version there is a description of the programs in chapter 8. In the OEM version the customer-specific documentation must be consulted.

Input circuits

Parameter assignment of the MSP in accordance with chapter 5.7.

Solenoid interlocks

Selection of the guard interlock type (see chapter 5.7):
power to lock or power to unlock principle



If the configuration is left without saving the old state remains valid.

Parameter

Analog inputs

Input type

Single sensor:	Single channel
Dual sensor:	Dual channel with specification of the tolerance of the channels.

Limit values

Limit values of the analogue inputs.

Inputs

Standard (S)	24 VDC for ON
Cross-wire short (C)	Cycle signal for ON. (see chapter 5.4)
Safety mat (M)	For safety mats in short circuit mode.

Times

Setting of the timer.

Default settings

Resets the device to the delivery status

Adjustment

Contrast

Stipulation of the contrast.

Screen saver

Waiting time until the screen saver becomes active.

Language

Setting of the language.

Info

Firmware version

Specification of the firmware version used.

Hardware info

Identification of the hardware.

Program version

Specification of the program including the hash totals (CRC) for program and parameter assignment.

Configuration

Display of the current configuration.

8. Appendix

8.1 Application programs

General information

The safety enable can only be given if all activated input circuits are closed and the analogue input values are below the limit values.



The programs listed here are valid only for the standard variant PROTECT SELECT and version 2.0 of the application program (printed safety seal "Appl V2.0"). If the CRC of the following application programs described in this document deviates from the indicated product program CRC then the following information in this operating manual does not apply.



When the START/RESET button is used, the requirements of EN ISO 13849-1 (manual reset) must be observed.



With a parameter setting of "Emergency-Stop":

The START/RESET button (I15) must be activated at all events after "Power On".



If no feedback circuit (EDM) is evaluated, then the corresponding input to 24VDC must be set to ensure the safety function of the activated / deactivated safe analogue inputs.



During the sequence of the after travel time (STOP 1) the actuation of all START/RESET buttons is ignored.



In case of a voltage drop or a system failure, the device shut off immediately without delay.

Sensor level: Safety digital inputs

In the following application programs, there is the possibility for the specified free sensors to include the following safety switching devices:

- Emergency stop command devices, electronic and safety switches with contacts, safety interlocks, proximity sensors, AOPDs, muting sensors and 4-wire safety mats.



According to EN 60204-1, a manual reset is necessary after triggering the emergency stop. If the emergency stop is configured with the option auto-start, a manual reset must be realised by other suitable measures.



The number of free sensors depends on the program.



If all sensors have the auto-start option in a protective area, then a START/RESET button for this protective area is not necessary.



Sensors and emergency stop command devices can be reset in any order.

Sensor level: Safe analogue inputs

Implemented in the following application programs for both analogue secure inputs are the following functions, coupled to the 4 limit values:

1. Limit (AI0-0 and AI1-0): Additional release interlock
2. Limit (AI0-1 and AI1-1): No function implemented
3. Limit (AI0-2 and AI1-2): No function implemented
4. Limit (AI0-3 and AI1-3): Emergency Stop

Description:

- **Additional release for the interlock:**
If an interlock is parameterized and the two analogue input values are below the first limit (AI0-0 and AI1-1) and are among the remaining limits, then the locking unit of the connected interlock can be unlocked.
- **Emergency-Stop-Function:**
If one of the analogue input values is above the fourth limit (AI0-3 or AI1-3) then this corresponds to the triggering of the Emergency Stop.



Connect the non-required analogue inputs to AGND and set the corresponding analogue limit values to 4095.



In the application programs, the error case of a wire break in the analogue input is not controlled. Selecting the "Dual Sensor" option allows wire breakage to be detected, but only a warning is displayed.



Sensors and emergency stop command devices can be reset in any order.

Actuator level

The actuator level for the subsequent application programs consists of:

- 1x p-/n-switching safe output Q0 / Q0N
- 2x p-switching safe outputs Q2 and Q3
- 2x Safe relay outputs QR1 and QR2
- 4x optional signalling outputs Y0 up to Y3

The number of shutdown paths depends on the application program selected:

- There are a maximum of five shutdown paths available.
- Every safe shutdown path can have an individual shutdown delay (Stop 1) assigned.
- The default times are set to 0.00 s, this means that the safe shutdown paths are shutdown without delay (Stop 0).

The output times are allocated to the following timers:

Output	Timer	Designation	Behaviour	Default
Q0/Q0N	T00	TOF 0	delayed OFF	0.00s
Q2	T02	TOF 2	delayed OFF	0.00s
Q3	T03	TOF 3	delayed OFF	0.00s
QR1	T04	TOF 4	delayed OFF	0.00s
QR2	T05	TOF 5	delayed OFF	0.00s
Y2	T06	TON 1	delayed ON	0.00s



Timer T00 up to T29: 0...599.99 s Step: 10 ms
Timer T31 and 32: 0...59999 s (ca. 16.6 h) Step: 1 s



DESCRIPTION:

TOF: Timer, shutdown delay
TON: Timer, switch on delay

With the setting: Safety door



If an "interlock" selection is active, the output Q0/Q0N does not behave like a safety release, because it is used to control the solenoid

Safety interlocks, 2-channel floating:

with solenoid and interlock monitoring and direct control of the interlock unit (magnet)

Power to unlock

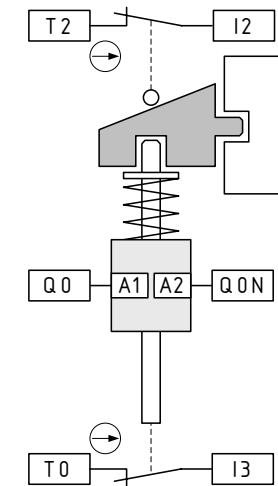

Power to lock

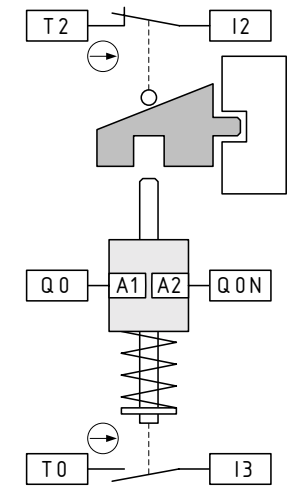

Interlock:

With electromechanical solenoid interlocks the magnet contact must be open. With a purely electronic solenoid interlock both inputs must have a LOW signal.



When using an electro-mechanical solenoid interlock the contact for the actuator must always be wired to the even input and the contact for the magnets on the odd input!

Application program 01

**Prog_01: A safety area, visible,
interlock + operating mode selector switch
4 x individual sensors,
1 x Emergency-Stop command device (variable sensors)**
(CRC 9FB6)

Connection example

Terminal assignment of the digital inputs

I0 + I1	Operating mode selector switch		
	automatic:	I0 = HIGH & I1 = LOW	
	manual:	I0 = LOW & I1 = HIGH	
I2 + I3	Enabling switches	MSP 6	(Default value = 0 0 0)
I4 + I5	1. sensor:	MSP 2	(Default value = 0 0 0)
I6 + I7	2. sensor:	MSP 3	(Default value = 0 0 0)
I8 + I9	3. sensor:	MSP 4	(Default value = 0 0 0)
I10 + I11	4. sensor:	MSP 5	(Default value = 0 0 0)
I12	Unlock solenoid interlock		
I13	Feedback circuit		
I14	---		
I15	START / RESET or latch interlock	for I16 + I17 and for I4 up to I11	
I16 + I17	Emergency stop command device,	MSP 1	(Default value = 0 A 1)

Terminal assignment of the outputs

Q0, Q0N	Stop 0 or Stop 1	with fail-safe timer T00
	Option with selection "Latch": working or quiescent current	
Q2	Stop 0 or Stop 1	with fail-safe timer T02
Q3	Stop 0 or Stop 1	with fail-safe timer T03
QR1	Stop 0 or Stop 1	with fail-safe timer T04
QR2	Stop 0 or Stop 1	with fail-safe timer T05

Terminal assignment of the signalling outputs (optionally digital input)

Y0 (I0)	---
Y1 (I4)	---
Y2 (I12)	---
Y3 (I14)	Signalling output: error message / status indication:
	Manual mode: Pulse sequence 2 Hz
	Warning: Pulse sequence 1 Hz
	Error messages: Constant HIGH level

Program description

The application program is based on a monitored visible safety area.

There is only a general requirement that lock and unlock all controlled interlocks.

The user has the option of connecting an interlock and operating mode selector switch as well as up to 4 sensors and an Emergency Stop command device.

Wiring example:

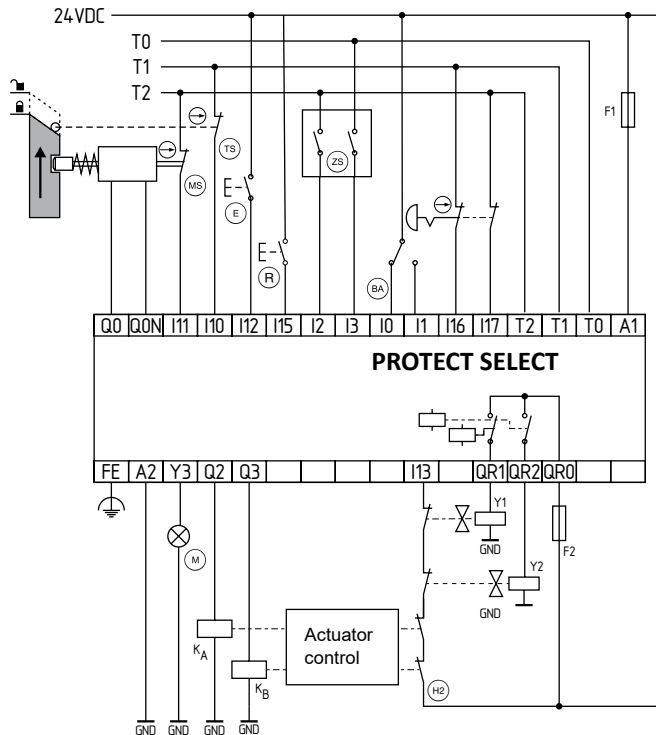

- | | | | |
|----|--------------------|----|--------------------------------|
| ⓉS | Door position | Ⓜ | Indicator lamp |
| ⓂS | Magnet position | ⓏS | consent switches |
| Ⓡ | Reset/Start button | ⓅA | Operating mode selector switch |
| ⓔ | Unlock | Ⓜ2 | Feedback circuit |

In addition, the inputs can be changed as individual sensors I16 and I17 together with the default setting "Emergency Stop command device". This sensor evaluation at inputs I16 and I17 has a higher priority and will not be bridged by the "operating mode selector switch + interlock" function.

Via the inputs I0 and I1 an operating mode selector switch is evaluated.

The selection of the operating mode selector switch is as follows:

- Automatic mode: I0 = HIGH and I1 = LOW
- Manual mode: I0 = LOW and I1 = HIGH

When the operating mode selector switch is set to "manual mode", the sensors can be bridged via the inputs I4 to I11 in their safety monitoring via an enabling switch to the inputs I2 and I3.

The condition START / RESET via the input I15 is permanently assigned to the inputs I16 + I17 and I4 to I11

The connected sensors I4 to I11 switch off the outputs Q0/Q0N, Q2 and Q3, QR1 and QR2.

Digital inputs I12, I13, I15

- Input I12 (unlock interlock: "Open door request"): Request to unlock the guard interlock so that the safety area can be accessed.
- Input I13 (feedback circuit): Feedback circuit from the actuators (e.g. guards, drive regulator, inverter, valve terminal etc.) is switched as an additional condition to the function macro.
- Input I15 (RESET for the Emergency-Stop command device and for the sensors I4 to I11):
 - Restart condition after the Emergency-Stop control device has been actuated.
 - Restart condition of the safety sensors, connected to the inputs I4 to I11.
 - Request for locking the guard interlock after leaving the safety area and the safety equipment has been closed.
- Unused inputs (MSP) must be set to code 000.

Signalling output Y3

- for the information transfer that an error has occurred with an error message or warning with a warning message on the display. This message output can also be used to control a corresponding fault or warning message lamp. Also via the signalling output Y3 the message "Manual operation is active" is transferred and displayed.

Signalling output Y3, error message / status indication:

- Manual mode: Flashing with 2Hz
- Warning: Flashing with 1Hz
- Error messages: Lights up

Safe semi-conductor outputs Q0/Q0N

- Stop 0 or Stop 1: All semiconductor outputs are linked to a safe timer (Timer Off Delay).
 - Stop 0: Timer = 0 seconds (Default value)
 - Stop 1: Timer should be actively adjusted to 0 seconds
- Additional function selection for a possible connected interlock: Working current Yes / No

Safe semi-conductor outputs Q2, Q3

- Stop 0 or Stop 1:
All semiconductor outputs are linked to a safe timer (Timer Off Delay).
Stop 0: Timer = 0 seconds (Default value)
Stop 1: Timer should be actively adjusted to 0 seconds

Safe relay outputs QR1, QR2

- Stop 0 or Stop 1:
All relay outputs are linked to a safe timer (Timer Off Delay).
Stop 0: Timer = 0 seconds (Default value)
Stop 1: Timer should be actively adjusted to 0 seconds

Timers used

Name	Function	Timer	Time [s]
TOF 0	Shut down delay for Q0/Q0N	T00	0.00
TOF 2	Shut down delay for Q2	T02	0.00
TOF 3	Shut down delay for Q3	T03	0.00
TOF 4	Shut down delay for QR1	T04	0.00
TOF 5	Shut down delay for QR2	T05	0.00
	Monitoring time for MSP 1 (E-Stop)	T07	10.00
	Monitoring time for MSP 2	T08	10.00
	Monitoring time for MSP 3	T09	10.00
	Monitoring time for MSP 4	T10	10.00
	Monitoring time for MSP 5	T11	10.00
	Monitoring time for MSP 6	T12	10.00
	Stable time for MSP 1 (E-Stop)	T13	0.10
	Stable time for MSP 2	T14	0.10
	Stable time for MSP 3	T15	0.10
	Stable time for MSP 4	T16	0.10
	Stable time for MSP 5	T17	0.10
	Stable time for MSP 6	T18	0.10
	Stable time for MSP 7 (analogue E-Stop)	T19	1.00



Employment of this user program requires observation of chapters 9.2.3, 9.2.4, 9.2.6.3 and 10.9 of EN 60204-1. Special requirements from these chapters must be realised by a higher ranking control.



When changing the operating mode, the outputs initiate a stop 0 or stop 1.



On the inputs I4 to I11 (first to fourth sensor) there should be no Emergency-Stop command device connected. Emergency-Stop command devices are only allowed to be connected to the inputs I16/I17.



After Power ON and after an operational mode change a START/RESET is necessary.



The enable device is to be configured as a contact safety switch (floating) with auto start.
Example: MSP code = 0 9 2 or 0 B 2

Functional diagram of application programme 1

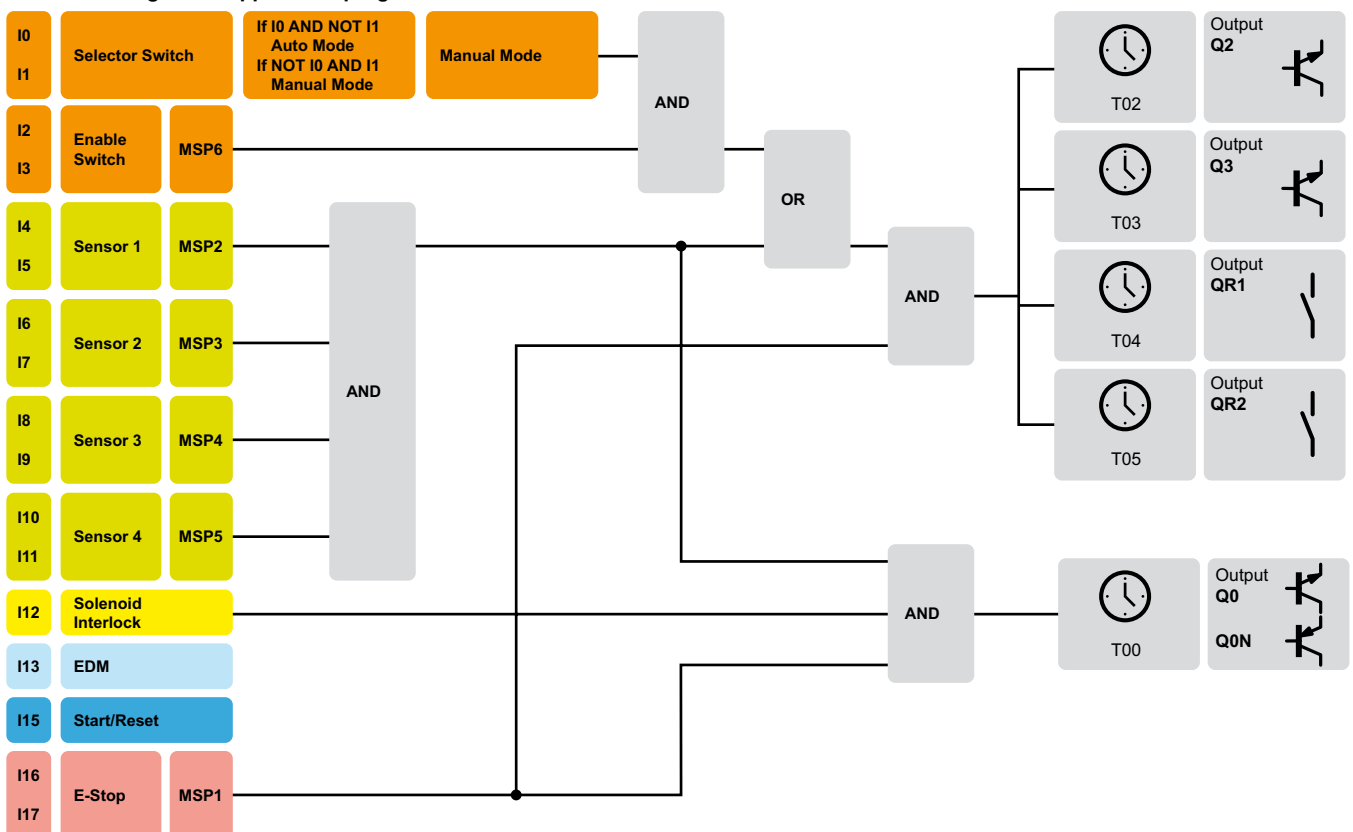

Application program 02

Prog_02: Two safety areas, visible,
2 x individual sensors for safety area 1, optional
3 x individual sensors for safety area 2, optional
1x Emergency-Stop command device (variable sensors), optional
 (CRC 006F)

Connection example

Terminal assignment of the digital inputs

I0	START / RESET for safety area 1 (SB1)		
I1	START / RESET for safety area 2 (SB2)		
I2 + I3	1.1 Sensor (SB1):	MSP 2	(Default value = 0 0 0)
I4 + I5	1.2 Sensor (SB1):	MSP 3	(Default value = 0 0 0)
I6 + I7	2.1 Sensor (SB2):	MSP 4	(Default value = 0 0 0)
I8 + I9	2.2 Sensor (SB2):	MSP 5	(Default value = 0 0 0)
I10 + I11	2.3 Sensor (SB2):	MSP 6	(Default value = 0 0 0)
I12	Feedback for safety area 1 (SB1)		
I13	Feedback for safety area 2 (SB2)		
I14	---		
I15	START / RESET	for I16 + I17	
I16 + I17	Emergency stop command device,	MSP 1	(Default value = 0 A 1)

Terminal assignment of the outputs

Q0, Q0N	Stop 0 or Stop 1 (SB1)	with fail-safe timer T00
Q2	Stop 0 or Stop 1 (SB2)	with fail-safe timer T02
Q3	Stop 0 or Stop 1 (SB2)	with fail-safe timer T03
QR1	Stop 0 or Stop 1 (SB2)	with fail-safe timer T04
QR2	Stop 0 or Stop 1 (SB2)	with fail-safe timer T05

Terminal assignment of the signalling outputs (optionally digital input)

Y0 (I0)	---	
Y1 (I4)	---	
Y2 (I12)	---	
Y3 (I14)	Signalling output: error message / status indication:	
	Error messages	Constant HIGH level
	Warnings	Pulse sequence 1 Hz

Program description

The application program is based on two monitored visible safety areas.

1. Safety area (SB1)

The user has the option of connecting 2 individual sensors to the inputs I2 to I5 in the first safety area. The connected sensors I2 to I5 switch off the outputs Q0/Q0N.

The condition START / RESET via the input I0 is permanently assigned to the inputs I2 to I5.

The feedback for the safety area 1 is implemented via the input I12.

2. Safety area (SB2)

The user has the option of connecting 3 individual sensors to the inputs I6 to I11 in the second safety area. The connected sensors I6 to I11 switch off the outputs Q2 and Q3, QR1 and QR2.

The condition START / RESET via the input I1 is permanently assigned to the inputs I6 to I11.

The feedback for the safety area 2 is implemented via the input I13.

First and second safety areas

The inputs I16 and I17 (default setting: Emergency Stop command device) switch off all the parent outputs Q0 to Q2 and QR1 to QR2.

The condition START / RESET via the input I15 is permanently assigned to the inputs I16 to I17.

In addition, the inputs can be changed as individual sensors I16 and I17 together with the default setting "Emergency Stop command device".

Digital inputs I0, I1, I13, I12, I15

- Input I0 (RESET), First safety area:
Restart condition of the safety sensors, connected to the inputs I2 to I5.
- Input I1 (RESET), Second safety area:
Restart condition of the safety sensors, connected to the inputs I6 to I11.
- Input I12 (feedback circuit). First safety area:
Feedback circuit from the actuators (e.g. guards, drive regulator, inverter, valve terminal etc.) is switched as an additional condition to the function macro.
- Input I13 (feedback circuit). Second safety area:
Feedback circuit from the actuators (e.g. guards, drive regulator, inverter, valve terminal etc.) is switched as an additional condition to the function macro.
- Input I15 (RESET for the Emergency-Stop command device with a higher priority):
Restart condition after the Emergency-Stop control device has been actuated.
- Unused inputs (MSP) must be set to code 000.

High priority for all safety areas:

- Signaling output Y3:
for the information transfer that an error has occurred with an error message or warning with a warning message on the display. This message output can also be used to control a corresponding fault or warning message lamp.

1. Safety area: Safe semi-conductor outputs Q0/Q0N

- Stop 0 or Stop 1:
All semiconductor outputs are linked to a safe timer (Timer Off Delay).
Stop 0: Timer = 0 seconds (Default value)
Stop 1: Timer should be actively adjusted to 0 seconds

2. Safety area: Safe semi-conductor outputs Q2, Q3

- Stop 0 or Stop 1:
All semiconductor outputs are linked to a safe timer (Timer Off Delay).
Stop 0: Timer = 0 seconds (Default value)
Stop 1: Timer should be actively adjusted to 0 seconds

2. Safety area: Safe relay outputs QR1, QR2

- Stop 0 or Stop 1:
All relay outputs are linked to a safe timer (Timer Off Delay).
Stop 0: Timer = 0 seconds (Default value)
Stop 1: Timer should be actively adjusted to 0 seconds

Timers used

Name	Function	Timer	Time [s]
TOF 0	Shut down delay for Q0/Q0N	T00	0.00
TOF 2	Shut down delay for Q2	T02	0.00
TOF 3	Shut down delay for Q3	T03	0.00
TOF 4	Shut down delay for QR1	T04	0.00
TOF 5	Shut down delay for QR2	T05	0.00
	Monitoring time for MSP 1 (E-Stop)	T07	10.00
	Monitoring time for MSP 2	T08	10.00
	Monitoring time for MSP 3	T09	10.00
	Monitoring time for MSP 4	T10	10.00
	Monitoring time for MSP 5	T11	10.00
	Monitoring time for MSP 6	T12	10.00
	Stable time for MSP 1 (E-Stop)	T13	0.10
	Stable time for MSP 2	T14	0.10
	Stable time for MSP 3	T15	0.10
	Stable time for MSP 4	T16	0.10
	Stable time for MSP 5	T17	0.10
	Stable time for MSP 6	T18	0.10
	Stable time for MSP 7 (analogue E-Stop)	T19	1.00

Diagram, application program 2

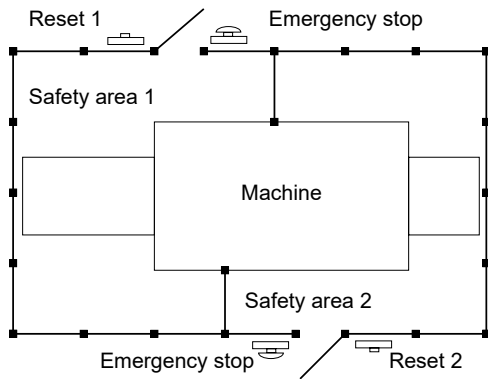

Wiring example:

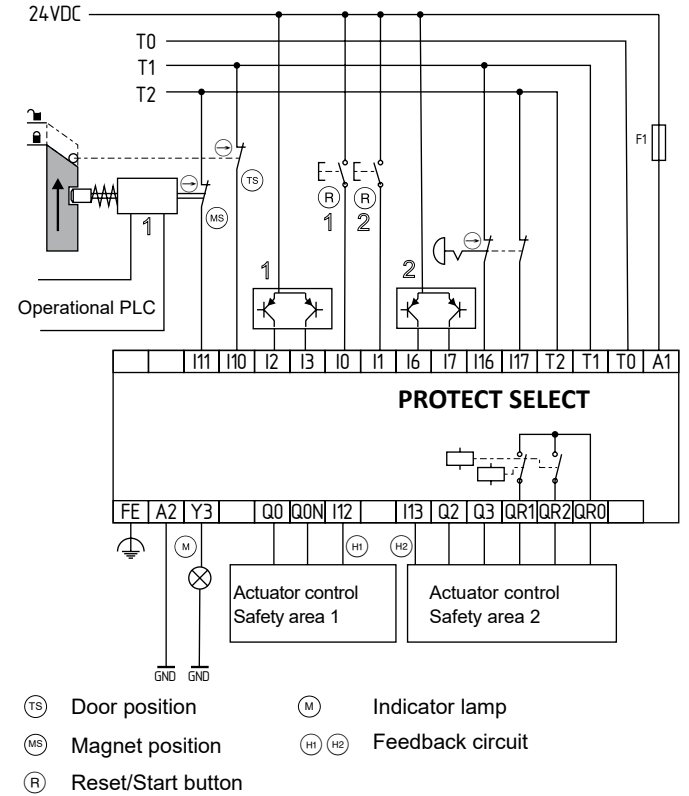

Functional diagram of application programme 2

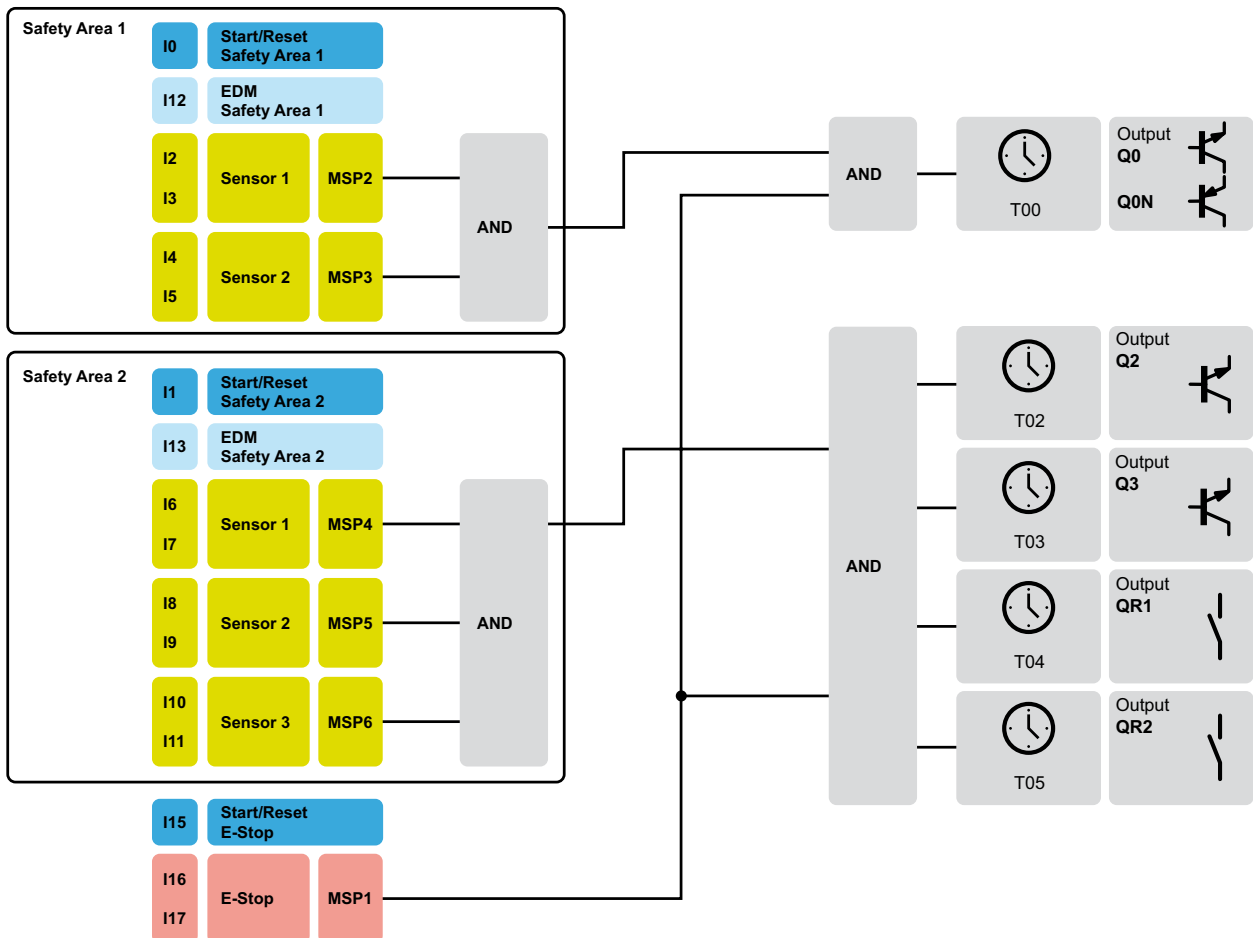

Application program 03

Prog_03: One safety area, visible,
1 x interlock,
5 x individual sensors, optional,
1 x Emergency-Stop command device (optional, variable sensors)

(CRC 055E)

Connection example

Terminal assignment of the digital inputs

I0	START / RESET or latch interlock	for I2 up to I11	
I1	Unlock solenoid interlock		
I2 + I3	1. sensor:	MSP 2	(Default value = 0 0 0)
I4 + I5	2. sensor:	MSP 3	(Default value = 0 0 0)
I6 + I7	3. sensor:	MSP 4	(Default value = 0 0 0)
I8 + I9	4. sensor:	MSP 5	(Default value = 0 0 0)
I10 + I11	5. sensor:	MSP 6	(Default value = 0 0 0)
I12	---		
I13	Feedback circuit		
I14	---		
I15	START / RESET or latch interlock	for I16 + I17	
I16 + I17	Emergency stop command device,	MSP 1	(Default value = 0 A 1)

Terminal assignment of the outputs

Q0, Q0N	Stop 0 or Stop 1	with fail-safe timer T00
	Option with selection "Latch": working or quiescent current	
Q2	Stop 0 or Stop 1	with fail-safe timer T02
Q3	Stop 0 or Stop 1	with fail-safe timer T03
QR1	Stop 0 or Stop 1	with fail-safe timer T04
QR2	Stop 0 or Stop 1	with fail-safe timer T05

Terminal assignment of the signalling outputs (optionally digital input)

Y0 (I0)	---
Y1 (I4)	---
Y2 (I12)	without delay OFF / delayed ON with timer T06
Y3 (I14)	Signalling output: error message / status indication:
	Error messages Constant HIGH level
	Warnings Pulse sequence 1 Hz

Program description

The application program is based on a monitored visible safety area.

There is only a general requirement that lock and unlock all controlled interlocks.

The user has the option of connecting 5 individual sensors to the inputs I2 to I11. The condition START / RESET via the input I0 is permanently assigned to the inputs I2 + I11.

In addition, the inputs can be changed as individual sensors I16 and I17 together with the default setting "Emergency Stop command device". The condition START / RESET via the input I15 is permanently assigned to the inputs I16 + I17.

The connected sensors switch off the outputs Q0/Q0N, Q2 and Q3, QR1 and QR2.

Digital inputs I0, I1, I13, I15

- Input I0 (RESET):
 - Restart condition of the safety sensors, connected to the inputs I2 to I11.
 - Request for locking the guard interlock after leaving the safety area and the safety equipment has been closed.
- Input I1 (unlock interlock: "Open door request"):
 - Request to unlock the guard interlock so that the safety area can be accessed.
- Input I13 (feedback circuit):
 - Feedback circuit from the actuators (e.g. guards, drive regulator, inverter, valve terminal etc.) is switched as an additional condition to the function macro.
- Input I15 (RESET for the Emergency-Stop command device):
 - Restart condition after the Emergency-Stop control device has been actuated.
- Unused inputs (MSP) must be set to code 000.

Signalling outputs Y2, Y3

- Signalling output Y2:
 - Function: Stop 0 and switch on delay via a safe timer such as for non-safe control of the operational input with drive regulators/inverters with the function: Emergency-Stop ramp/quick stop/release regulator with Emergency-Stop ramp
- Signalling output Y3:
 - for the information transfer that an error has occurred with an error message or warning with a warning message on the display. This message output can also be used to control a corresponding fault or warning message lamp.

Safe semi-conductor outputs Q0/Q0N

- Stop 0 or Stop 1:
 - All relay outputs are linked to a safe shutdown delay timer (Timer Off Delay).
- Additional function selection for a possible connected interlock:
 - Working current Yes / No

Safe semi-conductor outputs Q2, Q3 and safe relay outputs QR1, QR2

- Stop 0 or Stop 1:
 - All relay outputs are linked to a safe shutdown delay timer (Timer Off Delay).

Timers used

Name	Function	Timer	Time [s]
TOF 0	Shut down delay for Q0/Q0N	T00	0.00
TOF 2	Shut down delay for Q2	T02	0.00
TOF 3	Shut down delay for Q3	T03	0.00
TOF 4	Shut down delay for QR1	T04	0.00
TOF 5	Shut down delay for QR2	T05	0.00
TON 1	Run-up time for output Y2	T06	0.00
	Monitoring time for MSP 1 (E-Stop)	T07	10.00
	Monitoring time for MSP 2	T08	10.00
	Monitoring time for MSP 3	T09	10.00
	Monitoring time for MSP 4	T10	10.00
	Monitoring time for MSP 5	T11	10.00
	Monitoring time for MSP 6	T12	10.00
	Stable time for MSP 1 (E-Stop)	T13	0.10
	Stable time for MSP 2	T14	0.10
	Stable time for MSP 3	T15	0.10
	Stable time for MSP 4	T16	0.10
	Stable time for MSP 5	T17	0.10
	Stable time for MSP 6	T18	0.10
	Stable time for MSP 7 (analogue E-Stop)	T19	1.00



The delay for the signaling output Y2 (I12) is used for direct control of the restart interlock and the controller release so that the controller release with for example the drive regulator or the inverted can be issued with a delay.

Wiring example:

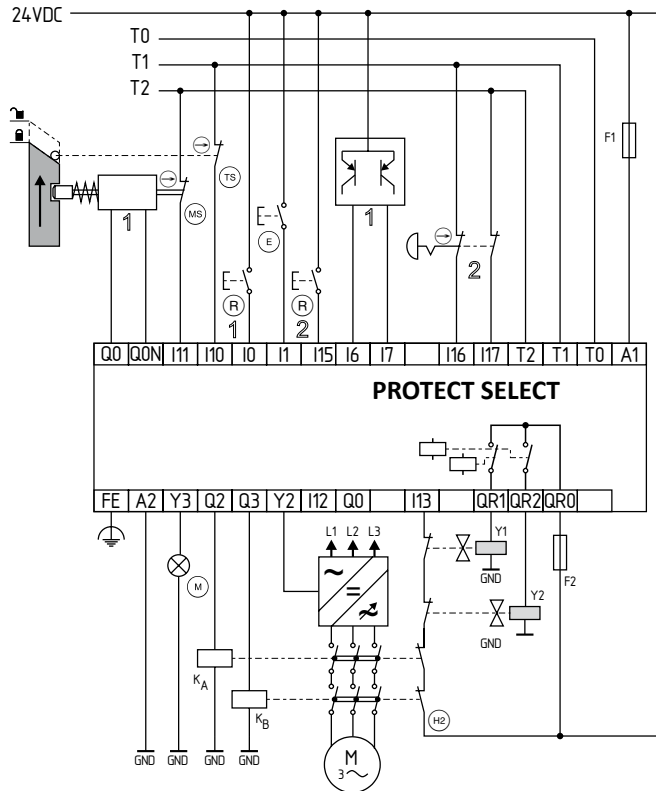

- TS Door position
- MS Magnet position
- R Reset/Start button
- E Unlock
- M Indicator lamp
- H2 Feedback circuit

Functional diagram of application programme 3

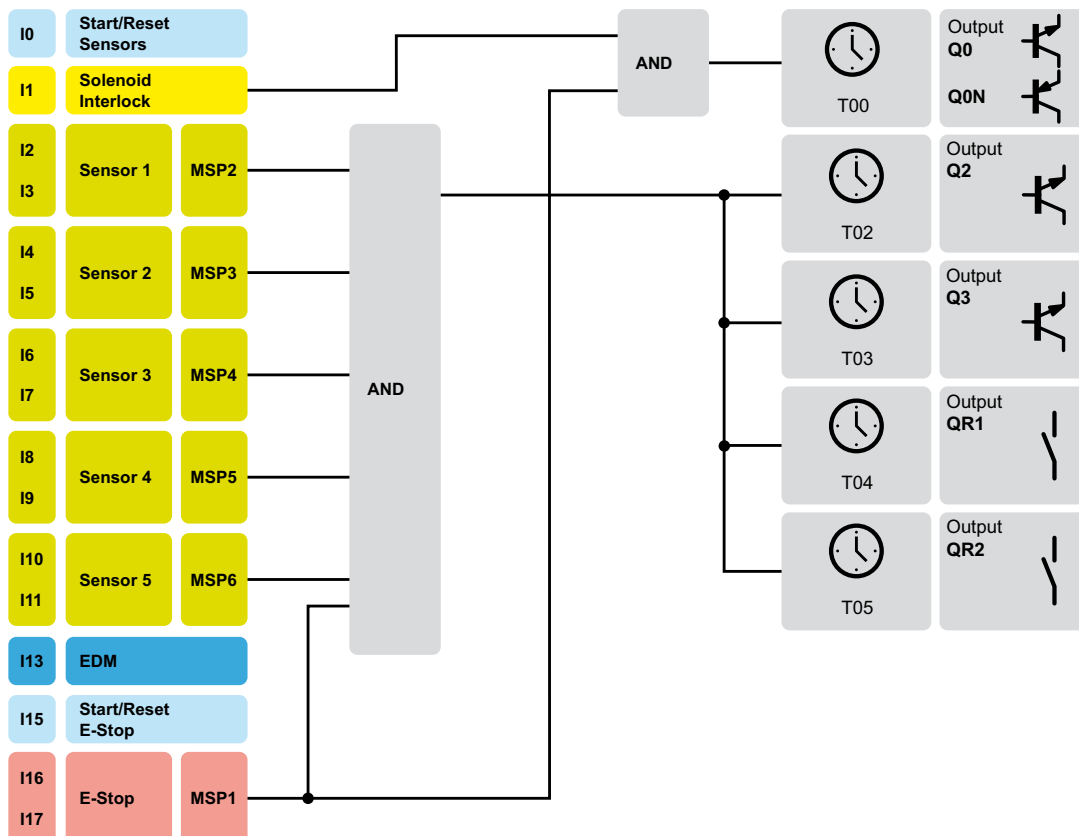

Application program 04

Prog_04: One safety area with muting, visible, 1 x interlock
1 x individual sensor, optional,
1 x Emergency-Stop command device (variable sensors),
optional
 (CRC 003F)

Connection example

Terminal assignment of the digital inputs

I0	---
I1	Muting: Stop monitoring time
I2	Muting sensor B2 (NC)
I3	Muting sensor B1 (NC)
I4	AOPD
I5	AOPD
I6	Muting sensor A2 (NC)
I7	Muting sensor A1 (NC)
I8	Activate override
I9	Unlock solenoid interlock
I10 + I11	Sensor 1: MSP 2 (Default value = 0 0 0)
I12	---
I13	Feedback circuit
I14	---
I15	START / RESET for muting, or latch interlock for I10+I11 and I16+I17
I16 + I17	Emergency stop command device, MSP 1 (Default value = 0 A 1)

Terminal assignment of the outputs

Q0, Q0N	Stop 0 or Stop 1 with fail-safe timer T00
	Option with selection "Latch": working or quiescent current
Q2	Stop 0 or Stop 1 with fail-safe timer T02
Q3	Stop 0 or Stop 1 with fail-safe timer T03
QR1	Stop 0 or Stop 1 with fail-safe timer T04
QR2	Stop 0 or Stop 1 with fail-safe timer T05

Terminal assignment of the signalling outputs (optionally digital input)

Y0 (I0)	Muting lamp
Y1 (I4)	---
Y2 (I12)	Delayed ON (timer T 06) / without delay OFF
Y3 (I14)	Signalling output: error message / status indication:
	Error messages Constant HIGH level
	Warnings Pulse sequence 1 Hz

Program description

The application program is based on a monitored visible safety area with muting function.

There is only a general requirement that lock and unlock all controlled interlocks.

The user has the option of connecting 1 individual sensor to the inputs I10 to I11.

In addition, the inputs can be changed as individual sensors I16 and I17 together with the default setting "Emergency Stop command device".

The condition START / RESET via the input I15 is permanently assigned to the inputs I16+I17, I10+I11 and for muting.

Digital inputs I9, I13, I15

- Input I9 (unlock interlock: "Open door request"):
 - Request to unlock the guard interlock so that the safety area can be accessed.

- Input I13 (feedback circuit):

Feedback circuit from the actuators (e.g. guards, drive regulator, inverter, valve terminal etc.) is switched as an additional condition to the function macro.

- Input I15 (RESET for the Emergency-Stop command device and for the individual sensors and for the muting function):
 - Restart condition after the Emergency-Stop control device has been actuated.
 - Restart condition of the safety sensors, connected to the inputs I10 to I11.
 - Request for locking the guard interlock after leaving the safety area and the safety equipment has been closed.
- The muting function is implemented via the inputs I1 to I8.
- Unused inputs (MSP) must be set to code 000.

Signalling outputs Y0, Y2, Y3

- Signalling output Y0:
 - Indication that the muting function is active.
- Signalling output Y2:
 - Function: Stop 0 and switch on delay via a safe timer such as for non-safe control of the operational input with drive regulators/inverters with the function: Emergency-Stop ramp/quick stop/release regulator with Emergency-Stop ramp
- Signaling output Y3:
 - for the information transfer that an error has occurred with an error message or warning with a warning message on the display. This message output can also be used to control a corresponding fault or warning message lamp.

Safe semi-conductor outputs Q0/Q0N

- Stop 0 or Stop 1:
 - All semiconductor outputs are linked to a safe timer (Timer Off Delay).
 - Stop 0: Timer = 0 seconds (Default value)
 - Stop 1: Timer should be actively adjusted to 0 seconds
- Additional function selection for a possible connected interlock:
 - Working current Yes / No

Safe semi-conductor outputs Q2, Q3

- Stop 0 or Stop 1:
 - All semiconductor outputs are linked to a safe timer (Timer Off Delay).
 - Stop 0: Timer = 0 seconds (Default value)
 - Stop 1: Timer should be actively adjusted to 0 seconds

Safe relay outputs QR1, QR2

- Stop 0 or Stop 1:
 - All relay outputs are linked to a safe timer (Timer Off Delay).
 - Stop 0: Timer = 0 seconds (Default value)
 - Stop 1: Timer should be actively adjusted to 0 seconds

Timers used

Name	Function	Timer	Time [s]
TOF 0	Shut down delay for Q0/Q0N	T00	0.00
TOF 2	Shut down delay for Q2	T02	0.00
TOF 3	Shut down delay for Q3	T03	0.00
TOF 4	Shut down delay for QR1	T04	0.00
TOF 5	Shut down delay for QR2	T05	0.00
TON 1	Run-up time for output Y2	T06	0.00
	Monitoring time for MSP 1 (E-Stop)	T07	10.00
	Monitoring time for MSP 2	T08	10.00
	Stable time for MSP 1 (E-Stop)	T13	0.10
	Stable time for MSP 2	T14	0.10
	Stable time for MSP 3 (analogue E-Stop)	T19	1.00
MUT 1	Muting: monitoring time	T31	600
MUT 2	Muting: Drop-out delay	T20	5.00
MUT 3	Muting: Override time	T21	5.00
MUT 4	Muting: sensor tolerance time	T22	0.50
MUT 5	Muting: Error tolerance time	T23	4.00



The delay for the signaling output Y2 (I12) is used for direct control of the restart interlock and the controller release so that the controller release with for example the drive regulator or the inverter can be issued with a delay.



The requirements according to EN 61496-1 must be observed.



The override function can be realised with a tip switch, which must be mounted in a position where the danger zones are visible.



The muting monitoring time should be set as short as possible!



The muting delay (dropout delay) may only be applied if the material is conveyed from the danger zone!



The muting delay should be kept as short as possible so that the condition of the muting can be immediately removed as soon as the material has left the safety zone..



Muting with dropout delay should not be used if the muting sensor is installed in front of the protection area outside the danger zone!



The timer value should be adapted to the application. Standard requirements should be taken into account.

Operating principle: Muting

Muting is the temporary bypassing of a safety light barrier if required by the duty cycle. There must be a voltage applied to the muting inputs A1 and A2 or A2 and B1 or B1 and B2. Muting may only take place if it is certain that during the duty cycle the hazardous area cannot be reached or dangerous movements cannot take place. This is the case when material passes through the safety light barrier of the protection area and between the material and the safety light barrier nothing can penetrate into the hazardous area or no dangerous movements can take place. The difference between conveyed material and a person or the recognition of a non dangerous movement condition occurs with two separate and independent muting sensors.

Muting with 4 sensors

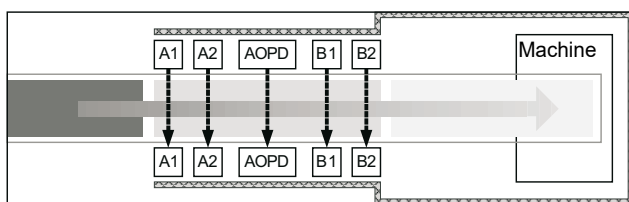

Muting with 2 sensors

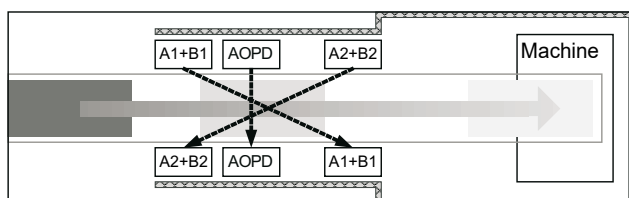

Initial condition

The protection area is free which means that the light grid / light curtain (AOPD) on the inputs I4+I5 is not interrupted and the muting sensors A1/A2 (I2+I3) and B1/B2 (I6+I7) are not actuated and the rest of the safety circuit (I10+I11 and I16+I17) is closed.

The safety monitoring is started when a falling edge occurs on the input I15. The outputs muting are set (Q0 to Q3, QR1 to QR2).

Operating situation

- A workpiece moves into the system and first actuates muting sensors A1/A2:
 - The muting monitoring time starts
 - The muting lamp (Y0) switches on.
 - The muting outputs remain set.
- The light grid (AOPD) is interrupted:
 - The muting monitoring time continues.
 - The muting lamp (Y0) remains on.
 - The muting outputs remain set.
- The workpiece now reaches both of the muting sensors B1/B2:
 - The muting monitoring time continues.
 - The muting lamp (Y0) remains on.
 - The muting outputs remain set.
- The workpiece leaves the muting sensors A1/A2:
 - The muting monitoring time continues.
 - The muting lamp (Y0) remains on.
 - The muting outputs remain set.
- The workpiece releases the light barrier (AOPD):
 - The muting monitoring time continues.
 - The muting lamp (Y0) remains on.
 - The muting outputs remain set.
- The workpiece leaves the muting sensors B1/B2:
 - The muting monitoring time stops.
 - The muting lamp (Y0) along with the Timer MUT 2 is switched off with a delay.
 - The muting outputs remain set.

Fault situation 1

- The light grid (AOPD) is interrupted:
 - The muting outputs are switched off.
 - The safety release is withdrawn and a restart is prevented.
 - The fault lamp (Y3) and the muting lamp (Y0) are not lit.

Fault situation 2

- Only one muting sensor (e.g. A1) is singularly set:
 - The muting outputs remain set.
 - The muting monitoring time (MUT 1) starts.
 - The muting sensor tolerance time (MUT 4) is started.
- The one muting sensor (e.g. A1) remains singularly set:
 - The muting sensor tolerance time (MUT 4) expires.
 - The muting outputs are switched off.
 - The safety release is withdrawn and a restart is prevented.
 - The fault lamp (Y3) illuminates.

Fault situation 3

- During muting (operational condition point 1 to 6):
 - Fault after the muting monitoring has expired (MUT 1).
 - The muting outputs are switched off.
 - The safety release is withdrawn and a restart is prevented.
 - The fault lamp (Y3) illuminates.
 - The muting lamp (Y0) switched off without delay.

Override

- With a HIGH signal on the Override input (I8) and if necessary actuation of the START/RESET button, the override function can be started which means the workpiece is moved out of the machine.
 - The muting outputs are set.
 - The warning message lamp (Y3) is switched off if necessary.

INFO:

The override function can be interrupted at any time by a LOW signal on Override input (I8).

In addition, a time limit by the override time takes place, which automatically stops the timeout sequence. Which means the override must be completed within the override time. The muting lamp (Y0) is turned off during the override.

- If the muting sensors and the light grids (AOPD) are free (initial condition), the override function is terminated by a LOW signal on the Override input (I8) and the operating situation is restored.

8.2 Error message, warning and status indication

Prog_01	Prog_02	Prog_03	Prog_04	Display indications (depending on the application program)	Comment
■				Error - operating mode selection	Both inputs on which the operating mode selector switch is connected have the same signal (both HIGH or both LOW).
■	■	■	■	Error - single-channel opening detected	With a 2-channel sensor a 1-channel drop is detected. A restart is only possible if the sensor is 2-channel open and then back to 2-channel closed
■	■	■	■	Error - antivalent safety switch	With a 2-channel equivalent sensor (2 NC) nonequivalence is detected. (Instead of 2 identical signals one signal is opposite, for example, channel A = HIGH and channel B = LOW) OR with a 2-channel nonequivalence sensor (1 NC and 1 NO) an equivalence is detected. (Instead of 2 different signals, both signals are the same)
■	■	■	■	Error - dual-channel control when single-channel is selected	The inputs for sensors (e.g. I2 and I3) were set as 1-channel sensors (MSP Code, 3rd place = 2). On the deactivated odd input (here I3) a high signal is detected.
■	■	■	■	Error - control of a disabled sensor	The inputs for sensors (e.g. I4 and I5) were not needed for the safety circuit and are set as deactivated. At one or both inputs a HIGH signal is detected.
■	■	■	■	Error - feedback circuit (EDM)	The safety circuit is closed and the safe outputs are open: To restart the safety monitoring the high signal is absent at the corresponding input, which means the feedback loop of the integrated actuator is not closed.
■	■	■	■	Timeout - Disturbed safety switch	The time lag between the signal changes of the two channels of a 2-channel sensor was larger than the set monitoring time.
			■	Error - Muting	A fault was detected in the muting sequence, which led to a halt (see fault case muting). Eliminate problem, press Override and confirm with START / RESET.
■		■	■	Warning - Interlock not locked	Setting the solenoid interlock parameters, for example, via the inputs I6 and I7: The interlock (magnet) is driven, but the interlock does not lock.
■	■	■	■	Warning - Safety circuit open	Part or all of the connected sensor is / are not yet closed.
■	■	■	■	Warning - Analogue Input: Emergency-Stop active	After exceeding the limits AI0-3 and AI1-3, an Emergency-Stop function was activated and the safe outputs were switched off.
■	■	■	■	Warning- RESET necessary	The safety circuit is closed. To restart the safety monitoring the START / RESET is missing.
■		■	■	Warning - Analogue input: Interlock not released	When setting solenoid interlock parameters, for example, via the inputs I6 and I7 and setting the limit parameters of AI0-0 and AI 1 0: After the limits AI0-0 and AI 1 0 are exceeded, the solenoid interlock can be unlocked via the corresponding input. If an unlock request is trigger via the corresponding input and the limit AI0-0 and AI1-0 are not reached, then a warning message is triggered.
■				Manual operation is active	At the inputs where the operating mode selector switch is connected, the position "Manual" has been detected, i.e. I0 = LOW and I1 = HIGH.

9. EU Declaration of conformity

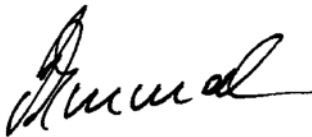
EU Declaration of conformity		
Original	K.A. Schmersal GmbH & Co. KG Möddinghofe 30 42279 Wuppertal Germany Internet: www.schmersal.com	
We hereby certify that the hereafter described components both in their basic design and construction conform to the applicable European Directives.		
Name of the component:	PROTECT SELECT-CC ¹⁾ ¹⁾ SYS firmware: 1.1.7 or higher Hardware: FOMP or higher	
Type:	See ordering code (standard version)	
Description of the component:	Multifunctional safety controller	
Relevant Directives:	Machinery Directive	2006/42/EC
	EMC-Directive	2014/30/EU
	RoHS-Directive	2011/65/EU
Applied standards:	EN ISO 13850:2015 EN ISO 13849-1:2023 IEC 61508 parts 1-7:2010	
Notified body for Type Examination:	TÜV Rheinland Industrie Service GmbH Am Grauen Stein, 51105 Köln ID n°: 0035	
EC-Type Examination Certificate:	01/205/5352.02/24	
Person authorised for the compilation of the technical documentation:	Oliver Wacker Möddinghofe 30 42279 Wuppertal	
Place and date of issue:	Wuppertal, July 9, 2024	
PROTECT-SELECT-K-EN		
	Authorised signature Philip Schmersal Managing Director	



The currently valid declaration of conformity can be downloaded from the internet at products.schmersal.com.

The PROTECT SELECT OEM is supplied with a separate declaration of conformity.

