



**EN** Operating instructions. . . . . pages 1 bis 9  
Original

**Content**

**1 About this document**

1.1 Function . . . . . 1

1.2 Target group: authorised qualified personnel. . . . . 1

1.3 Explanation of the symbols used . . . . . 1

1.4 Appropriate use . . . . . 1

1.5 General safety instructions . . . . . 1

1.6 Warning about misuse . . . . . 1

1.7 Exclusion of liability . . . . . 2

**2 Product description**

2.1 Ordering code . . . . . 2

2.2 Special versions. . . . . 2

2.3 Comprehensive quality insurance to 2006/42/EC . . . . . 2

2.4 Purpose and use . . . . . 2

2.5 Technical data . . . . . 3

2.6 Safety classification of the safety function . . . . . 3

**3 Mounting**

3.1 General mounting instructions. . . . . 3

3.2 Dimensions . . . . . 3

3.3 Mounting of the pushbutton and illuminated pushbutton caps for option -2875. . . . . 3

3.4 Mounting ramp edge . . . . . 4

3.5 Inscription plates . . . . . 4

**4 Electrical connection**

4.1 General information for electrical connection. . . . . 4

4.2 Serial diagnostic SD interface . . . . . 4

**5 Combinations and functions of control elements**

5.1 Combination possibilities of control elements . . . . . 5

5.2 Safety function . . . . . 5

5.3 Mode of operation of the safety outputs. . . . . 5

5.4 Function of the command and signalling devices . . . . . 5

5.5 Function of G24 indicator lamp . . . . . 5

**6 Diagnostic functions**

6.1 Diagnostic functions of SD interface . . . . . 6

6.2 Data layout SD interface . . . . . 6

6.3 Data layout FB interface . . . . . 7

6.4 SFB field bus data . . . . . 7

**7 Set-up and maintenance**

7.1 Functional testing. . . . . 8

7.2 Maintenance . . . . . 8

**8 Disassembly and disposal**

8.1 Disassembly. . . . . 8

8.2 Disposal . . . . . 8

**9 Appendix**

9.1 Pin assignment SD variant. . . . . 8

9.2 Pin assignment FB variant. . . . . 8

**10 EU Declaration of conformity**

**1. About this document**

**1.1 Function**

This operating instructions manual provides all the information you need for the mounting, set-up and commissioning to ensure the safe operation and disassembly of the safety switchgear. The operating instructions must be available in a legible condition and a complete version in the vicinity of the device.

**1.2 Target group: authorised qualified personnel**

All operations described in this operating instructions manual must be carried out by trained specialist personnel, authorised by the plant operator only.

Please make sure that you have read and understood these operating instructions and that you know all applicable legislations regarding occupational safety and accident prevention prior to installation and putting the component into operation.

The machine builder must carefully select the harmonised standards to be complied with as well as other technical specifications for the selection, mounting and integration of the components.

**1.3 Explanation of the symbols used**

 **Information, hint, note:**  
This symbol indicates useful additional information.

 **Caution:** Failure to comply with this warning notice could lead to failures or malfunctions.  
**Warning:** Failure to comply with this warning notice could lead to physical injury and/or damage to the machine.

**1.4 Appropriate use**

The Schmersal range of products is not intended for private consumers.

The products described in these operating instructions are developed to execute safety-related functions as part of an entire plant or machine. It is the responsibility of the manufacturer of a machine or plant to ensure the correct functionality of the entire machine or plant.

The safety switchgear must be exclusively used in accordance with the versions listed below or for the applications authorised by the manufacturer. Detailed information regarding the range of applications can be found in the chapter "Product description".

**1.5 General safety instructions**

The user must observe the safety instructions in this operating instructions manual, the country specific installation standards as well as all prevailing safety regulations and accident prevention rules.

 Further technical information can be found in the Schmersal catalogues or in the online catalogue on the Internet: [products.schmersal.com](http://products.schmersal.com).

The information contained in this operating instructions manual is provided without liability and is subject to technical modifications.

There are no residual risks, provided that the safety instructions as well as the instructions regarding mounting, commissioning, operation and maintenance are observed.

**1.6 Warning about misuse**

 In case of improper use or manipulation of the safety switchgear, personal hazards or damages to machinery or plant components cannot be excluded.

x.000 / 09.2025 / v.A. - 103015929-EN / G / 2025-09-11 / AE-Nr. 19587

### 1.7 Exclusion of liability

We shall accept no liability for damages or malfunctions resulting from defective mounting or failure to comply with this operating instructions manual. We shall accept no liability for damages or malfunctions resulting from defective mounting or failure to comply with this operating instructions manual.

For safety reasons, invasive work on the device as well as arbitrary repairs, conversions and modifications to the device are strictly forbidden, the manufacturer shall accept no liability for damages resulting from such invasive work, arbitrary repairs, conversions and/or modifications to the device.

## 2. Product description

### 2.1 Ordering code

This operating instructions manual applies to the following types:

**BDF200-①-②-③-④-⑤-⑥-⑦**

No.	Option	Description
①	SD FB	Variant for SD interface Variant for safety fieldbox SFB
②	<b>Pos. 1</b> NH NHK	<b>Command device</b> Emergency stop without protective collar Emergency stop latching pushbutton with protective collar
	DT.. PT.. B	Pushbuttons Mushroom pushbutton Blanking plug
③	<b>Pos. 2</b> LT.. LM.. DT.. PT.. WS 2./ 3. WT. 2./ 3.	<b>Command and signalling device:</b> Illuminated pushbutton Indicator lights Pushbuttons Mushroom pushbutton Maintained selector switch, 2 or 3 positions Maintained spring-return rotary selector switch, 2 or 3 positions
	SWS / SWT 20 B	Key-operated selector switch 2 positions Blanking plug
④	<b>Pos. 3</b> LT.. LM.. DT.. PT.. WS 2./ 3. WT. 2./ 3.	<b>Command and signalling device:</b> Illuminated pushbutton Indicator lights Pushbuttons Mushroom pushbutton Maintained selector switch, 2 or 3 positions Maintained spring-return rotary selector switch, 2 or 3 positions
	SWS / SWT 20 B	Key-operated selector switch 2 positions Blanking plug
⑤	<b>Pos. 4</b> LT.. LM.. DT.. PT.. B	<b>Command and signalling device:</b> Illuminated pushbutton Indicator lights Pushbuttons Mushroom pushbutton Blanking plug
⑥	G24 G24R/B G24Y	without indicator lamp Indicator lamp G24, red/green Indicator lamp G24, red/blue Indicator lamp G24, yellow
⑦	2875	Pushbutton caps for pushbuttons and illuminated pushbuttons included in the kit



The unused positions 1 - 4 are labelled "B" and are sealed with a blanking plug in factory.



Only if the information described in this operating instructions manual are followed correctly, the safety function and therefore the compliance with the Machinery Directive is maintained.

### 2.2 Special versions

For special versions, which are not listed in the ordering code below 2.1, these specifications apply accordingly, provided that they correspond to the standard version.

### 2.3 Comprehensive quality insurance to 2006/42/EC

Schmersal is a certified company to appendix X of the Machinery Directive. As a result, Schmersal is entitled to autonomously conduct the conformity assessment procedure for the products listed in Appendix IV of the MD without involving a notified body. The prototype test certificates are available upon request or can be downloaded from the Internet at products.schmersal.com.

### 2.4 Purpose and use

The modular BDF200-SD/FB control panel is installed on the safety guard of a machine or plant. It enables the operator to activate functions such as, for instance, emergency stop, on/off and reset. The BDF200-FB (FB only) is intended for use with the SCHMERSAL SFB.

The emergency stop command device is used on machinery and plants as a safe command device to generate a safe signal initiating the shutdown of a hazardous movement when actuated.

The emergency stop command device may only be operated in connection with a safety monitor.



The user must evaluate and design the safety chain in accordance with the relevant standards and the required safety level.



The entire concept of the control system, in which the safety component is integrated, must be validated to the relevant standards.



#### Maintenance

Please observe that the safety function must be triggered at least once a year to test the system!

### 2.5 Technical data

Standards:	EN 60947-5-1, EN 60947-5-5, EN ISO 13850, EN ISO 13849-1, EN 61508
Material of the enclosure:	glass-fibre reinforced thermoplastic, self-extinguishing
Mechanical life:	Emergency stop: 100,000 operations Command devices: 1 million operations Rotary switch: 30,000 operations
Connection:	Connector plug M12, 8-pole, A-coded
Lamp socket:	BA5S, LED, max. length 17 mm
LED change:	from front
LED power consumption (operating elements):	16 mA
Power consumption G24:	20 mA
Response time:	≤ 50 ms
Duration of risk:	≤ 100 ms

#### Ambient conditions:

Ambient temperature:	-25 °C ... +65 °C
Storage and transport temperature:	-25 °C ... +85 °C
Climatic resistance:	to EN 60068 Part 2-30
Degree of protection:	IP65
Protection class:	III
Resistance to vibration:	10 ... 150 Hz (0.35 mm / 5 g)
Resistance to shock:	30 g / 11 ms
Insulation values to EN 60664-1:	
- Rated insulation voltage $U_i$ :	32 VDC
- Rated impulse withstand voltage $U_{imp}$ :	800 V
- Overvoltage category:	III
- Degree of pollution:	3

#### Electrical data:

Rated operating voltage $U_e$ :	24 VDC -15% / +10% (PELV to EN 60204-1)
Rated operating current $I_e$ :	0.6 A
Required rated short-circuit current:	100 A
No-load current $I_o$ :	35 mA

#### Safety inputs X1/X2:

Rated operating voltage $U_{e1}$ :	24 VDC -15% / +10% (PELV unit)
Current consumption per input:	5 mA
Test pulse duration:	≤ 1.0 ms
Test pulse interval:	≥ 100 ms
Classification:	ZVEI CB24I

Sink:	C1	Source:	C1	C2	C3
-------	----	---------	----	----	----

#### Safety outputs Y1/Y2:

	p-type, short-circuit proof
Operating current $I_{e1}$ :	max. 0.25 A
Leakage current $I_r$ :	< 0.5 mA
Utilisation category:	DC-12: $U_e/I_e$ : 24 VDC / 0.25 A, DC-13: $U_e/I_e$ : 24 VDC / 0.25 A

Minimum operating current $I_m$ :	0.5 mA
Voltage drop $U_d$ :	< 1 V
Test pulse duration:	≤ 1.0 ms
Test pulse interval:	1,000 ms
Classification:	ZVEI CB24I

Source:	C2	Sink:	C1	C2
---------	----	-------	----	----

#### Serial diagnostic:

	short-circuit proof
Device category SD variant:	Hex: 41
Operating current:	150 mA
Wiring capacitance:	max. 50 nF



For use in NFPA79, Industrial Machinery, only.  
The power-source has to be an isolated secondary source limited by a listed fuse rated 4A min. 24VAC/DC.  
Adapters providing field wiring means are available from the manufacturer. Refer to manufacturer's information.

### 2.6 Safety classification of the safety function

Standards:	EN ISO 13849-1, EN 61508
PL:	e
Category:	4
PFH:	≤ 2.89 x 10 <sup>-10</sup> / h up to max. 5,000 switching cycles/year
SIL:	suitable for SIL 3 applications
Mission time:	20 years

## 3. Mounting

### 3.1 General mounting instructions

There are two mounting holes for M5 screws in the device for attachment of the BDF200-SD/FB. Any position is possible.



The relevant requirements of the standard EN ISO 12100 must be observed.

### 3.2 Dimensions

All measurements in mm.

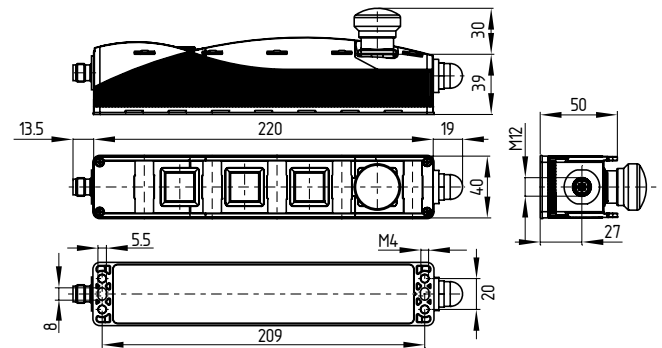

### 3.3 Mounting of the pushbutton and illuminated pushbutton caps for option -2875



The caps for the pushbuttons and illuminated pushbuttons are only suitable for a one-time mounting. Disassembly of the caps could cause damages to the component.  
The caps must be mounted immediately after unpacking the control panel, in order to avoid soiling of the inner pushbutton compartment by gross dirt particles / dust.

The caps for the pushbuttons and illuminated pushbuttons are mounted in the following manner:

1. Take the pushbutton or illuminated pushbutton cap as well as the rubber disk out of the kit
2. Take the control panel out of the protective packaging
3. Place the rubber disk on the pushbutton surface
4. Install the pushbutton or illuminated pushbutton cap onto that
5. Fix the cap



The cap "clicks" when it is engaged

6. Check the smooth actuation of the pushbutton
7. Repeat this procedure for all other pushbuttons



After the pushbutton or illuminated pushbutton cap is mounted, the proper fitting and the smooth actuation of the pushbutton must be checked. The button must return autonomously from the actuated to the non-actuated state and the cap must be at the same height as the component edging.

### 3.4 Mounting ramp edge

Remove the cover of the enclosure a and b (screws: Torx 10).



When opening the enclosure cover, please avoid damage to the connecting cables.



#### Caution!

Electrostatically sensitive components.  
Do not touch the printed circuit board.

Use 2 x M5 cylindrical screws ISO 4762 (DIN 912) for the assembly.

After fitting, the cover screws must be tightened with a tightening torque of 0.7 ... 0.8 Nm.



When closing the enclosure cover, please observe that the individual cables are not caught between the command device and the contact element.

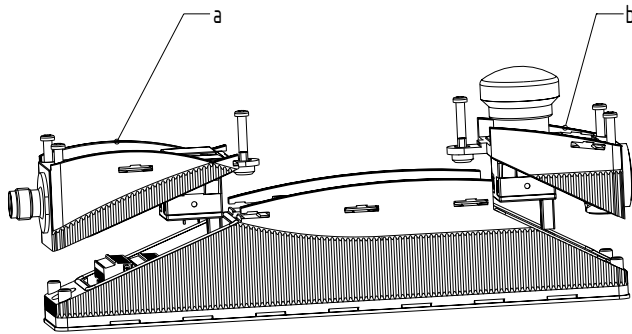

When closing the enclosure cover, ensure that the emergency stop module is flush with the bottom section and that the cover screws are screwed in as far as they will go.  
The emergency stop safety function must be checked by an appointed safety technician / safety representative once successfully installed.

### 3.5 Inscription plates

The marking on the inscription plates (included in delivery) is carried out by colour change by laser. The effects of heat may change the colour of the surface.

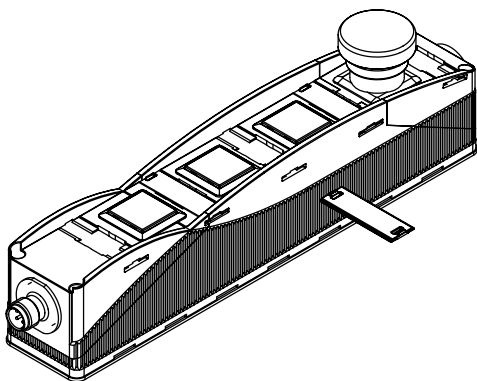

It must be ensured that the top is inscribed.

## 4. Electrical connection

### 4.1 General information for electrical connection



The electrical connection may only be carried out by authorised personnel in a de-energised condition.

The safety outputs can be integrated into the safety circuit of the control system. To meet the demands of EN ISO 13849-1 for PL e / category 4, the safety outputs of the control panel and control panel chain must be connected to a monitor of the same category.

Protection is not required when pilot wires are laid. The cables however must be separated from the supply and energy cables. The max. fuse rating of a device chain for protection of the cable depends on the cross section of the cables used.

#### Requirements for the connected safety-monitoring module

- Dual-channel safety input, suitable for p-type devices with electronic safety outputs (OSSD)



Information for the selection of suitable safety-monitoring modules can be found in the Schmersal catalogues or in the online catalogue on the Internet: [products.schmersal.com](http://products.schmersal.com).

The control panel tests its safety outputs through cyclic deactivation. The safety-monitoring module therefore does not need to be equipped with a cross-wire short detection. The switch-off times must be tolerated with the safety-monitoring module. The deactivation time of the control panel is also extended depending on the cable length and the capacity of the cable used. Typically, a switch-off time of 250 µs is reached with a 30-m connecting cable.



#### Configuration of the safety-monitoring module

If the control panel is connected to electronic safety-monitoring modules, we recommend a discrepancy time of 100 ms. The safety inputs of the safety-monitoring module must be able blanking a test impulse of approx. 1 ms. The safety-monitoring module does not need to have a cross-wire short monitoring function, if necessary, the cross-wire short monitoring function must be disabled.

### 4.2 Serial diagnostic SD interface

#### Cable design in case of serial diagnostics



When wiring SD devices, please observe the voltage drop on the cables and the current carrying capacity of the individual components.

The wiring capacitance of the connecting cable of the safety sensor must not exceed 50 nF.

Depending on the strand structure, normal unshielded 200 m long control cables LIYY 0.25 mm<sup>2</sup> to 1.5 mm<sup>2</sup> have a wiring capacitance of approx. 20 - 50 nF.



#### Accessories SD interface

For ease of wiring and series-wiring of SD devices considerable accessories are available.

Detailed information is available on the Internet, [products.schmersal.com](http://products.schmersal.com).



## 6. Diagnostic functions

### 6.1 Diagnostic functions of SD interface

Safety switchgear devices with serial diagnostic cable have a serial input and output instead of the conventional diagnostic output. If these safety switchgear devices are wired in series, the safety channels as well as the inputs and outputs of the diagnostic channels are wired in series.

Up to 31 safety switchgear devices can be connected in series with serial diagnostics. For the evaluation of the serial diagnostics line either the PROFIBUS-Gateway SD-I-DP-V0-2 or the Universal-Gateway SD-I-U-... are used. This SD-Gateway is integrated as a slave in an existing field bus system. In this way, the diagnostic signals can be evaluated by means of a PLC.

The necessary software for the integration of the SD-Gateway is available for download at [products.schmersal.com](http://products.schmersal.com).

The query details for each safety sensor are transmitted to the device via one output byte of the PLC respectively.

The request data for each safety sensor are transmitted to the device through an output byte of the PLC.

Should a communication error occur between the SD Gateway and the safety switchgear, the safety switchgear retains its switch status for the safety outputs.

### 6.2 Data layout SD interface

**Table 1: Overview of status signals, warnings or error messages of SD variant**

Communication directions:

Request byte: from PLC to local safety switchgear

Response byte: from local safety switchgear to PLC

Warning/error byte: from local safety switchgear to PLC

Bit n°	Request byte (Output bit control)	Response byte (Input bit control)	Diagnostic	
			Error warnings	Error messages
Bit 0:	—	Safety output Emergency stop <b>not</b> actuated	Error output Y1	Error output Y1
Bit 1:	LED G24 red	NO contact from pos. 2	Error output Y2	Error output Y2
Bit 2:	LED G24 green, blue, yellow	NC contact from pos. 2	Cross-wire Y1/Y2	Cross-wire Y1/Y2
Bit 3:	LED illuminated pushbutton pos. 2	NO contact from pos. 3	Temperature too high	Temperature too high
Bit 4:	LED illuminated pushbutton pos. 3	NC contact from pos. 3	—	Error emergency stop button
Bit 5:	LED illuminated pushbutton pos. 4	NO contact from pos. 4	Internal device error	Internal device error
Bit 6:	—	Error warning	Communication error between field bus Gateway and SD slave	—
Bit 7:	Error reset	Error (enabling path switched off)	Operating voltage limit	—

### Diagnostic error warning and error

If an error (warning) is signalled in the response byte, detailed fault information can be read out.

Detailed information about the use of the serial diagnostics can be found in the operating instructions of the PROFIBUS-Gateway SD-I-DP-V0-2 and the Universal-Gateway SD-I-U-....

### Error warning

A fault has occurred, which causes the safety outputs to be disabled after 30 minutes. The safety outputs initially remain enabled. This enables the shutdown of the process in a controlled manner. An error warning is deleted when the cause of error is eliminated.

### Error

A fault has occurred, which causes the safety outputs to be disabled. The fault is reset, when the cause is eliminated and bit 7 of the query byte changes from 1 to 0 or the safety function is actuated again. Faults at the safety outputs are only deleted upon the next release, as the fault rectification cannot be detected sooner.



On the FB variant of the BDF200-SD/FB, the two diagnosis bytes 'Error warnings' and 'Error messages' are not transferred.

### 6.3 Data layout FB interface

Communication directions:

Request byte: from PLC to local safety switchgear

Response byte: from local safety switchgear to PLC



With the FB variants, only the request and response bytes are transmitted by the SFB.

Bit assignment: BDF200-FB

Bit n°	Request byte (Output bit of the controller)	Response byte (Input bit of the controller)
Bit 0:	---	Safety output Emergency stop <b>not</b> actuated
Bit 1:	LED G24 red	NO contact from pos. 2
Bit 2:	LED G24 green, blue, yellow	NC contact from pos. 2
Bit 3:	LED illuminated push button pos. 2	NO contact from pos. 3
Bit 4:	LED illuminated push button pos. 3	NC contact from pos. 3
Bit 5:	LED illuminated push button pos. 4	NO contact from pos. 4
Bit 6:	---	Error warning
Bit 7:	Error reset	Error (enabling path switched off)

### 6.4 SFB field bus data

PLC output data BDF200-FB (PLC → SFB → BDF200-FB)

- FB interface output data

Device port	PROFINET O-Address (4 Byte)	EtherNet/IP Assembly A 152 (6 Byte)	EtherCAT Module 3 (4 I + 4 O Bytes)
X4	Slot: 1 3 Byte: n + 0	Functional data Tag: :O.Data[1].x	FB-I outputs Label: Port X4.x
X5	Slot: 1 3 Byte: n + 1	Functional data Tag: :O.Data[2].x	FB-I outputs Label: Port X5.x
X6	Slot: 1 3 Byte: n + 2	Functional data Tag: :O.Data[3].x	FB-I outputs Label: Port X6.x
X7	Slot: 1 3 Byte: n + 3	Functional data Tag: :O.Data[4].x	FB-I outputs Label: Port X7.x

PLC input data BDF200-FB (BDF200-FB → SFB → PLC)

- FB interface input data

Device port	PROFINET I-Address (6 Byte)	EtherNet/IP Assembly A 151 (10 Byte)	EtherCAT Module 3 (4 I + 4 O Bytes)
X4	Slot: 1 3 Byte: n + 2	Functional data Tag: :I.Data[4].x	FB-I inputs Label: Port X4.x
X5	Slot: 1 3 Byte: n + 3	Functional data Tag: :I.Data[5].x	FB-I inputs Label: Port X5.x
X6	Slot: 1 3 Byte: n + 4	Functional data Tag: :I.Data[6].x	FB-I inputs Label: Port X6.x
X7	Slot: 1 3 Byte: n + 5	Functional data Tag: :I.Data[7].x	FB-I inputs Label: Port X7.x



Detailed information about the field bus data and bit assignment can be found in the system handbook "Safety fieldbox SFB" at [products.schmersal.com](http://products.schmersal.com).

### 7. Set-up and maintenance

#### 7.1 Functional testing

The safety function of the safety components must be tested. The following conditions must be checked and met:

- Correct fixing of the fitted component
- Check the integrity of the cables and connections
- Check the command and signalling devices for damage
- For the types with extension ...-2875, the proper fitting and the smooth operation of the pushbuttons must be checked after the installation of the pushbutton and illuminated pushbutton caps

#### 7.2 Maintenance

The function of the emergency stop button must be tested in regular intervals.



**Maintenance:** Please observe that the safety function must be triggered at least once a year to test the system!

In case of correct installation in accordance with the instructions described above, the component requires little maintenance. Under extreme conditions, we recommend routine maintenance as follows:

- Check the correct fixing of the control panel
- Remove particles of dust and soiling.
- Check the integrity of the cables and connections
- For the types with extension ...-2875, the smooth operation of the pushbuttons and the illuminated pushbuttons must be checked.

**Damaged or defective components must be replaced.**

### 8. Disassembly and disposal

#### 8.1 Disassembly

The safety switchgear must be disassembled in a de-energised condition only.

#### 8.2 Disposal

The safety switchgear must be disposed of in an appropriate manner in accordance with the national prescriptions and legislations.

### 9. Appendix

#### 9.1 Pin assignment SD variant

Function safety switchgear		Pin configuration of the connector 	Colour code of the Schmersal connector plug to DIN 47100	Colour code of the Schmersal connector plug	Possible colour codes of other customary connector plugs to EN 60947-5-2
Signal SD device			From part no. 103007xxx	To part no. 103006xxx	
A1	U <sub>e</sub>	1	WH	BN	BN
X1	Safety input 1	2	BN	WH	WH
A2	GND	3	GN	BU	BU
Y1	Safety output 1	4	YE	BK	BK
OUT	SD output	5	GY	GY	GY
X2	Safety input 2	6	PK	VT	PK
Y2	Safety output 2	7	BU	RD	VT
IN	SD input	8	RD	PK	OR

#### 9.2 Pin assignment FB variant

Function safety switchgear		Pin configuration of the connector 	Colour code of the Schmersal connector plug to DIN 47100	Colour code of the Schmersal connector plug	Possible colour codes of other customary connector plugs to EN 60947-5-2
Signal FB device			From part no. 103007xxx	To part no. 103006xxx	
A1	U <sub>e</sub>	1	WH	BN	BN
X1	Safety input 1	2	BN	WH	WH
A2	GND	3	GN	BU	BU
Y1	Safety output 1	4	YE	BK	BK
OUT	FB input / output	5	GY	GY	GY
X2	Safety input 2	6	PK	VT	PK
Y2	Safety output 2	7	BU	RD	VT
IN	n. c.	8	RD	PK	OR

10. EU Declaration of conformity

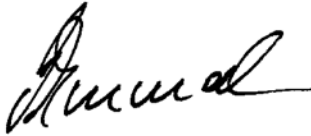
<b>EU Declaration of conformity</b>		
Original	K.A. Schmersal GmbH & Co. KG Möddinghofe 30 42279 Wuppertal Germany Internet: www.schmersal.com	
We hereby certify that the hereafter described components both in their basic design and construction conform to the applicable European Directives.		
<b>Name of the component:</b>	BDF200-SD BDF200-FB	
<b>Type:</b>	See ordering code	
<b>Description of the component:</b>	Control panel with or without safety function and integrated SD interface or FB interface	
<b>Relevant Directives:</b>	Machinery Directive <sup>1)</sup> 2006/42/EC Low Voltage Directive 2014/35/EU EMC-Directive 2014/30/EU RoHS-Directive 2011/65/EU <sup>1)</sup> for device versions with safety function (emergency stop)	
<b>Applied standards:</b>	EN 60947-5-1:2017 + AC:2020 <sup>1)</sup> EN 60947-5-5:1997 + A1:2005 + A11:2013 + A2:2017 <sup>1)</sup> EN ISO 13849-1:2023 <sup>1)</sup> EN 61508-1:2010	
<b><sup>1)</sup> Notified body for Type Examination:</b>	TÜV Rheinland Industrie Service GmbH Am Grauen Stein 51105 Köln ID n°: 0035	
<b><sup>1)</sup> EC-Type Examination Certificate:</b>	01/205/5613.01/24	
<b>Person authorised for the compilation of the technical documentation:</b>	Oliver Wacker Möddinghofe 30 42279 Wuppertal	
<b>Place and date of issue:</b>	Wuppertal, May 23, 2024	
BDF200-SD_FB-E-EN		
	Authorised signature <b>Philip Schmersal</b> Managing Director	



The currently valid declaration of conformity can be downloaded from the internet at [products.schmersal.com](http://products.schmersal.com).

